

The Online VLS Spectrometer @ FLASH

Spectral distribution shot per shot

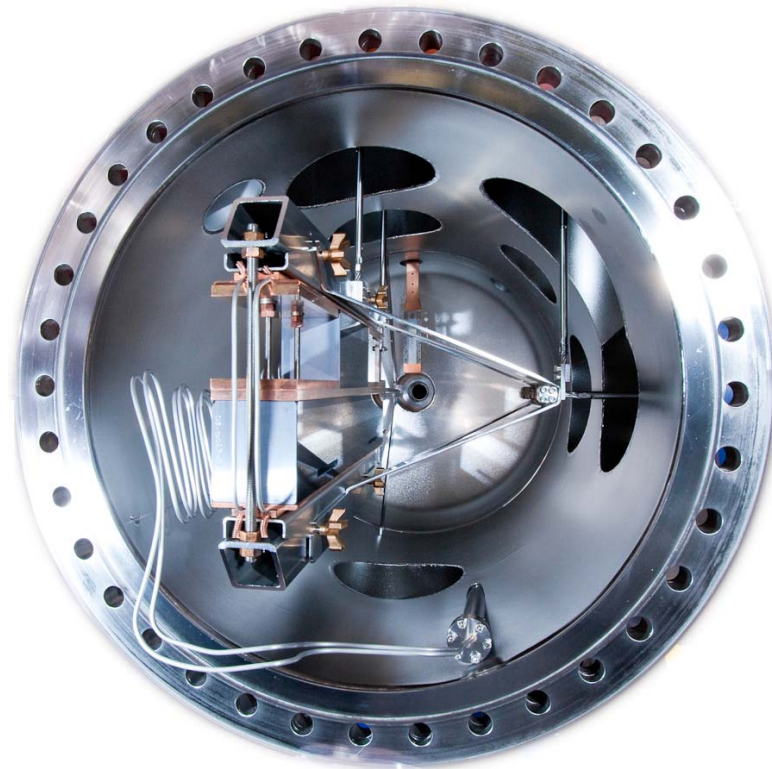

Günter Brenner

People involved in this work

DESY

G. Brenner

S. Kapitzki

*M. Kuhlmann**

K. Tiedtke

R. Treusch

J. Feldhaus

FLASH team

FS-BT

BESSY/HZB

F. Siewert

T. Noll

K. Blümer

STFC

M. Bowler

F. Quinn

M. Roper

SAS

R. Reiningger

**presently @ALBA/Barcelona*



Photon Diagnostics @FLASH

Gas monitor detector (GMD)

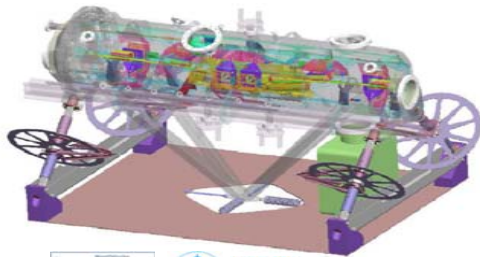
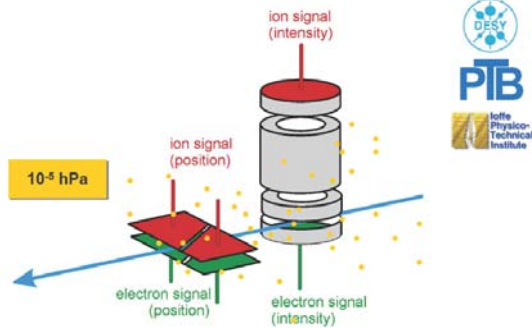

Non-linear autocorrelation

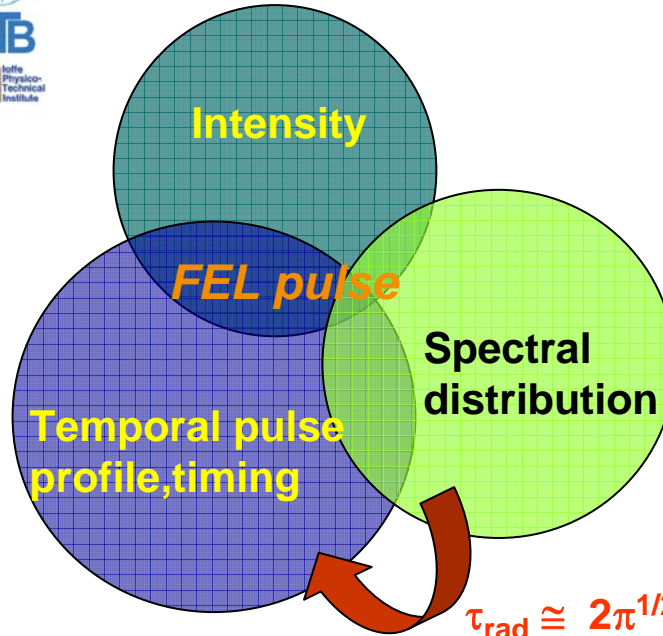

$$\tau_{\text{rad}} \cong 2\pi^{1/2}/(\Delta\omega)_{\text{FWHM}}$$

Photoelectron spectra

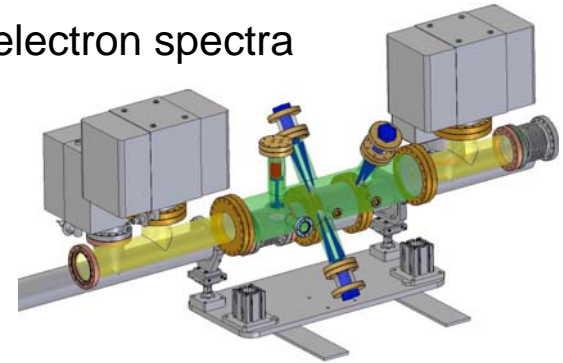

OPIS (P. Juranic)

Grating spectrometer

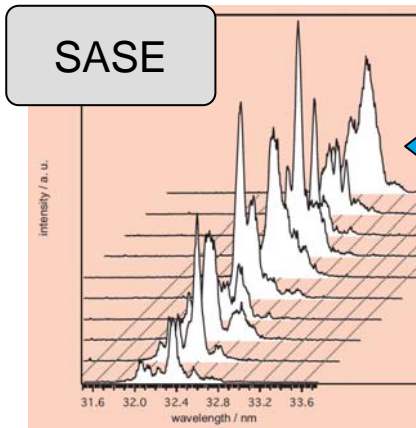

ONLINE MEASUREMENTS
NON-DESTRUCTIVE

Users/operators



Principle idea of the grating spectrometer

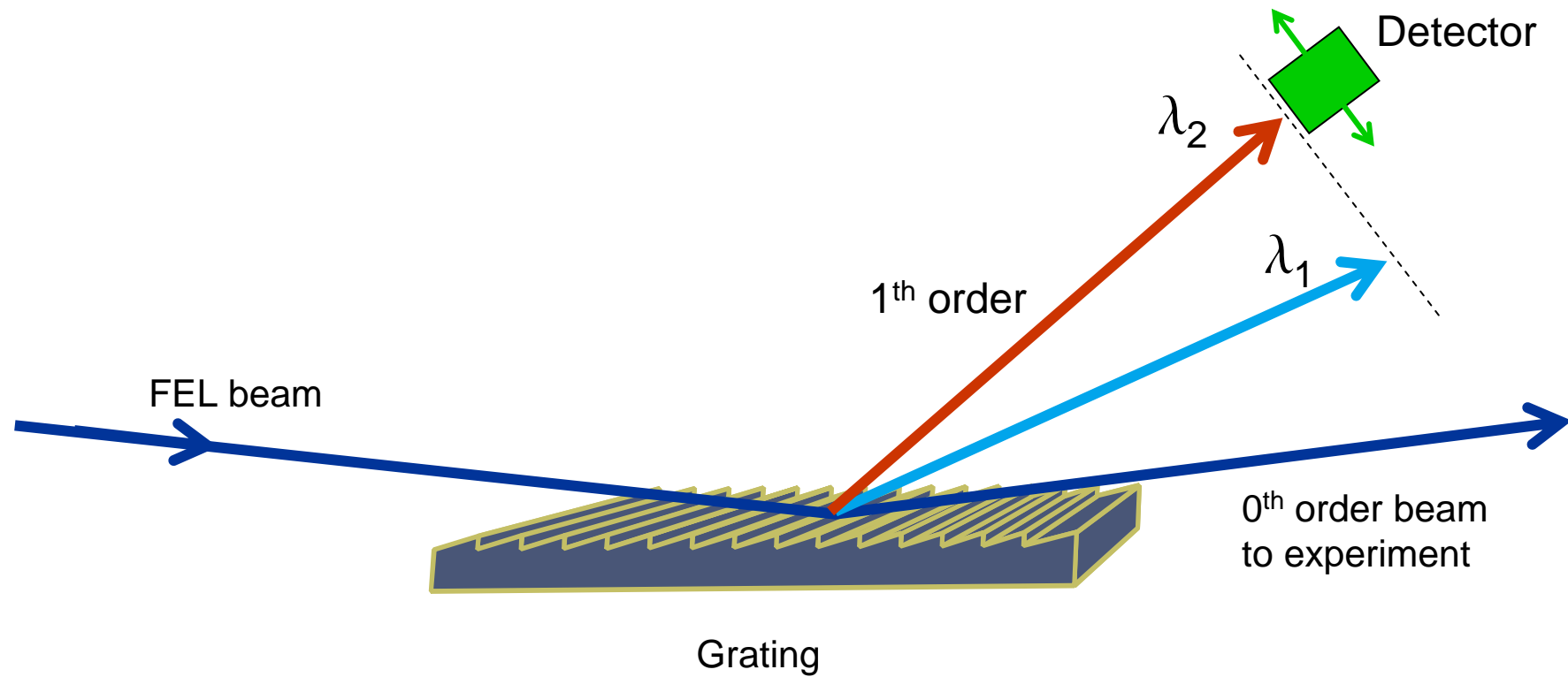

Variable Line Spacing Grating

Grating equation $\sin\alpha - \sin\beta = m\lambda\sigma_0$

Groove density σ

$$\sigma(y) = \sigma_0 + \sigma_1 y + \sigma_2 y^2 + \sigma_3 y^3$$

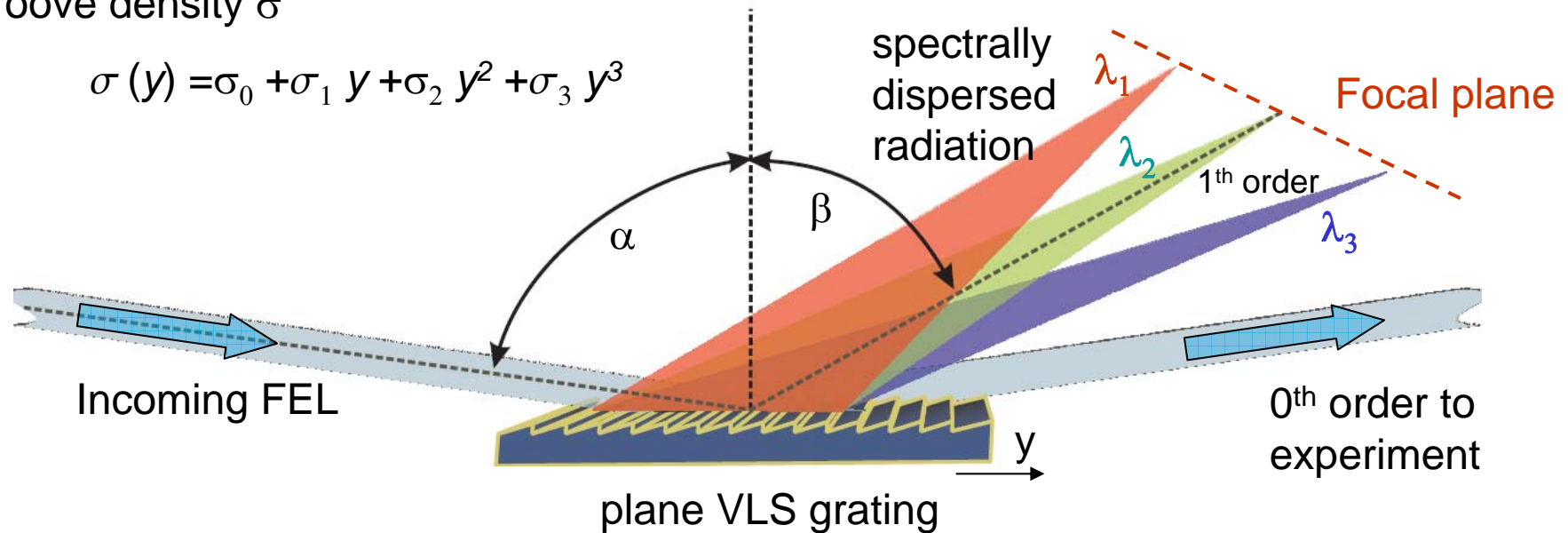

- $\sigma(y)$ chosen such that **spectral defocusing is zero & aberration effects are minimized**
- **1 - 10%** of incoming radiation **is dispersed** (depending on λ)
- Detector follows the focal plane of the grating



Overview: FLASH & VLS-Spectrometer

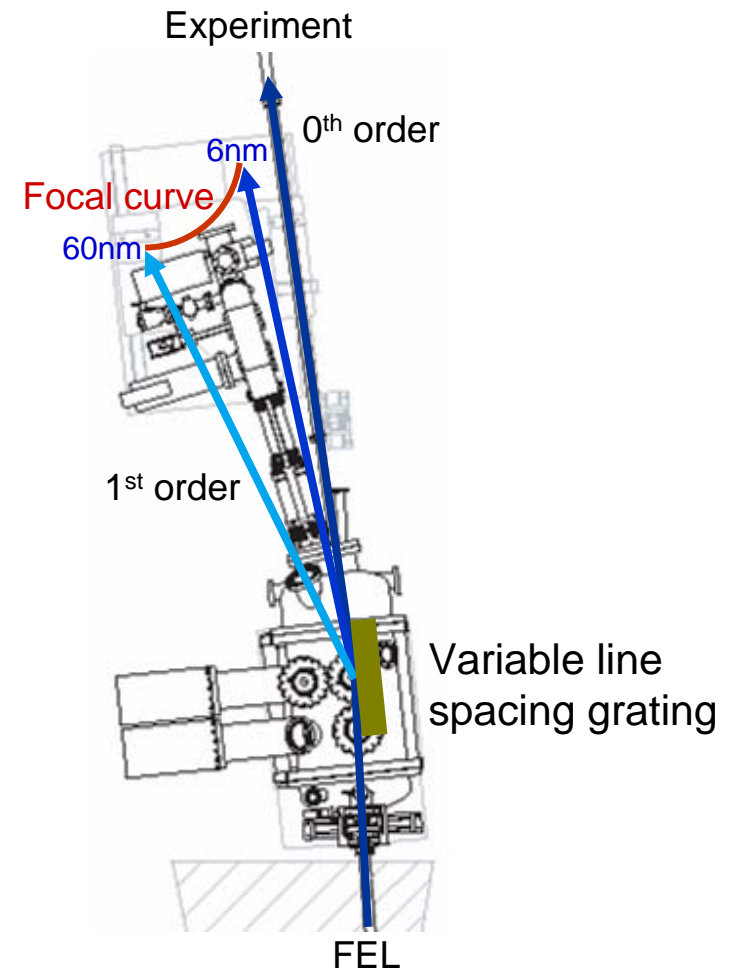
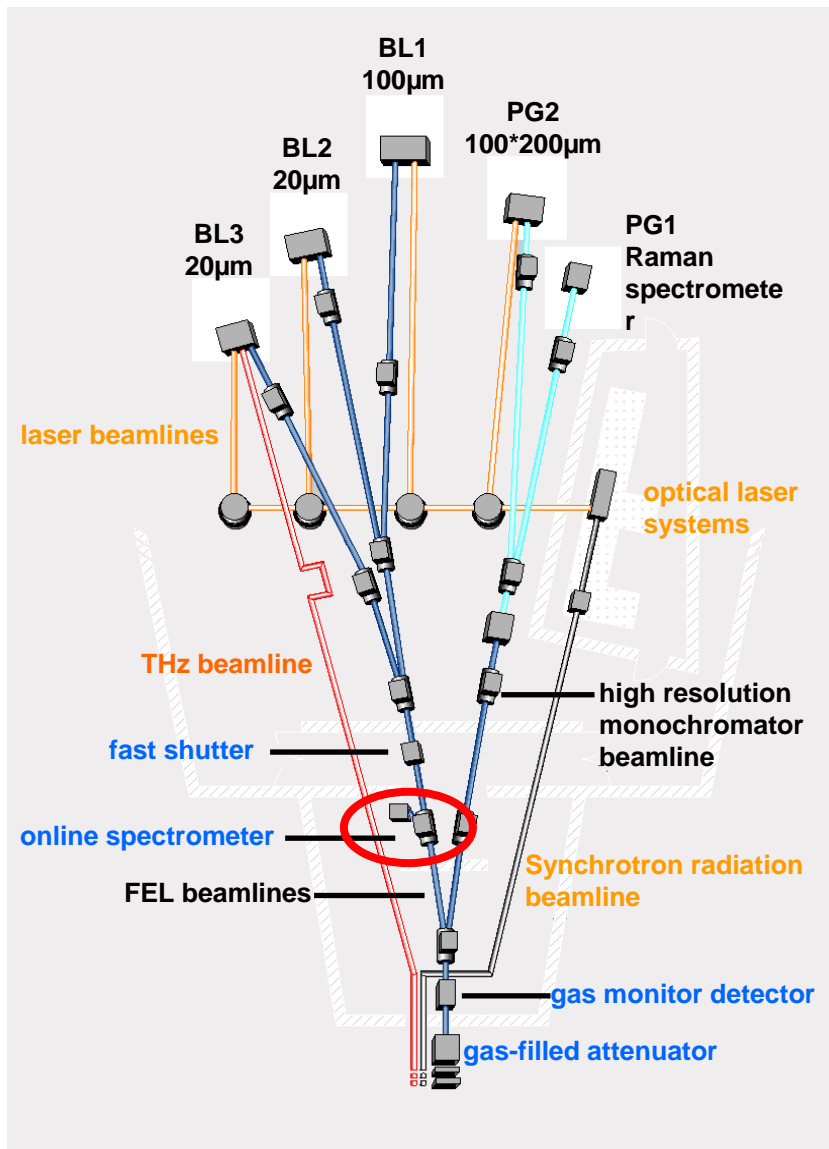

The Online VLS Spectrometer

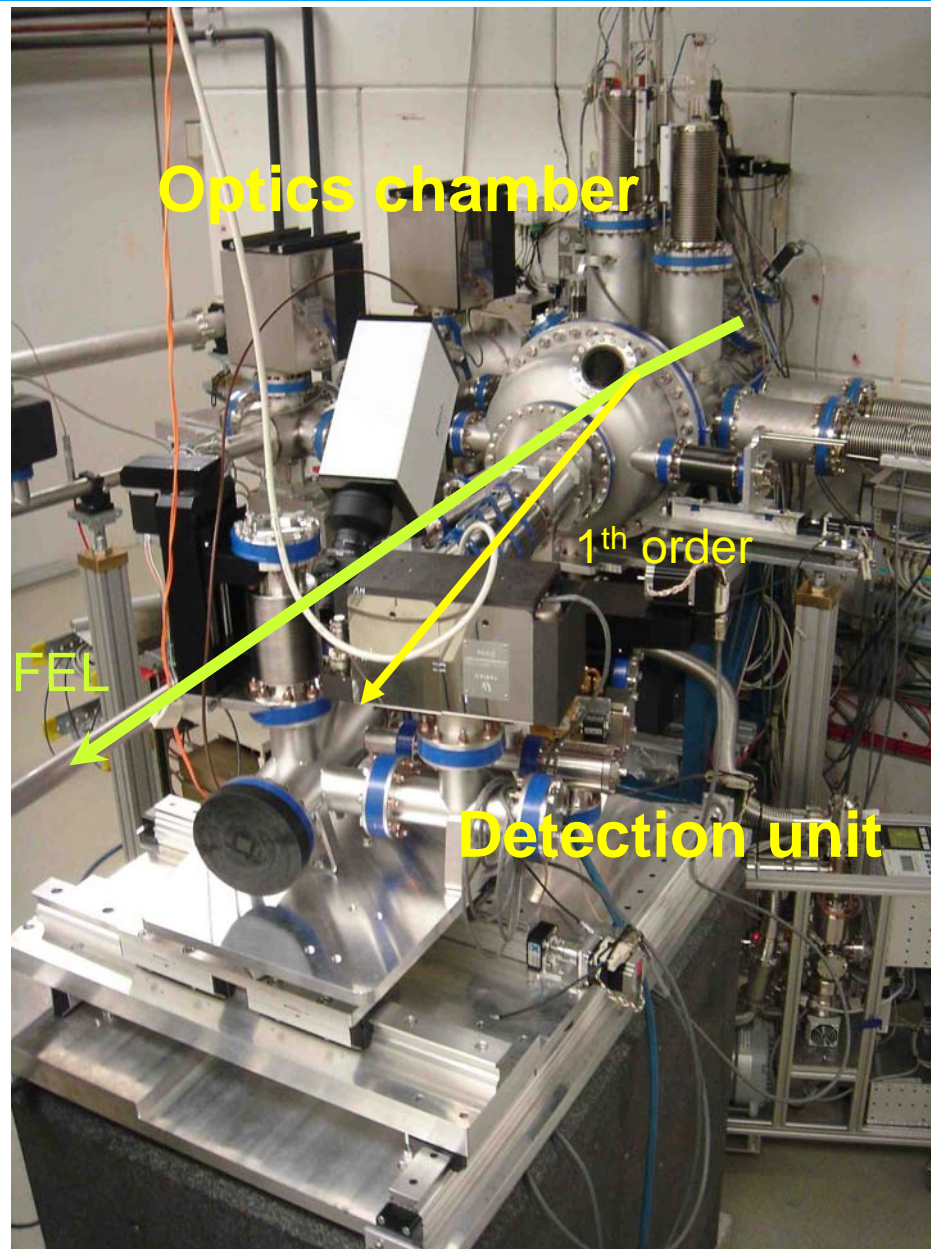

Instrumental Design

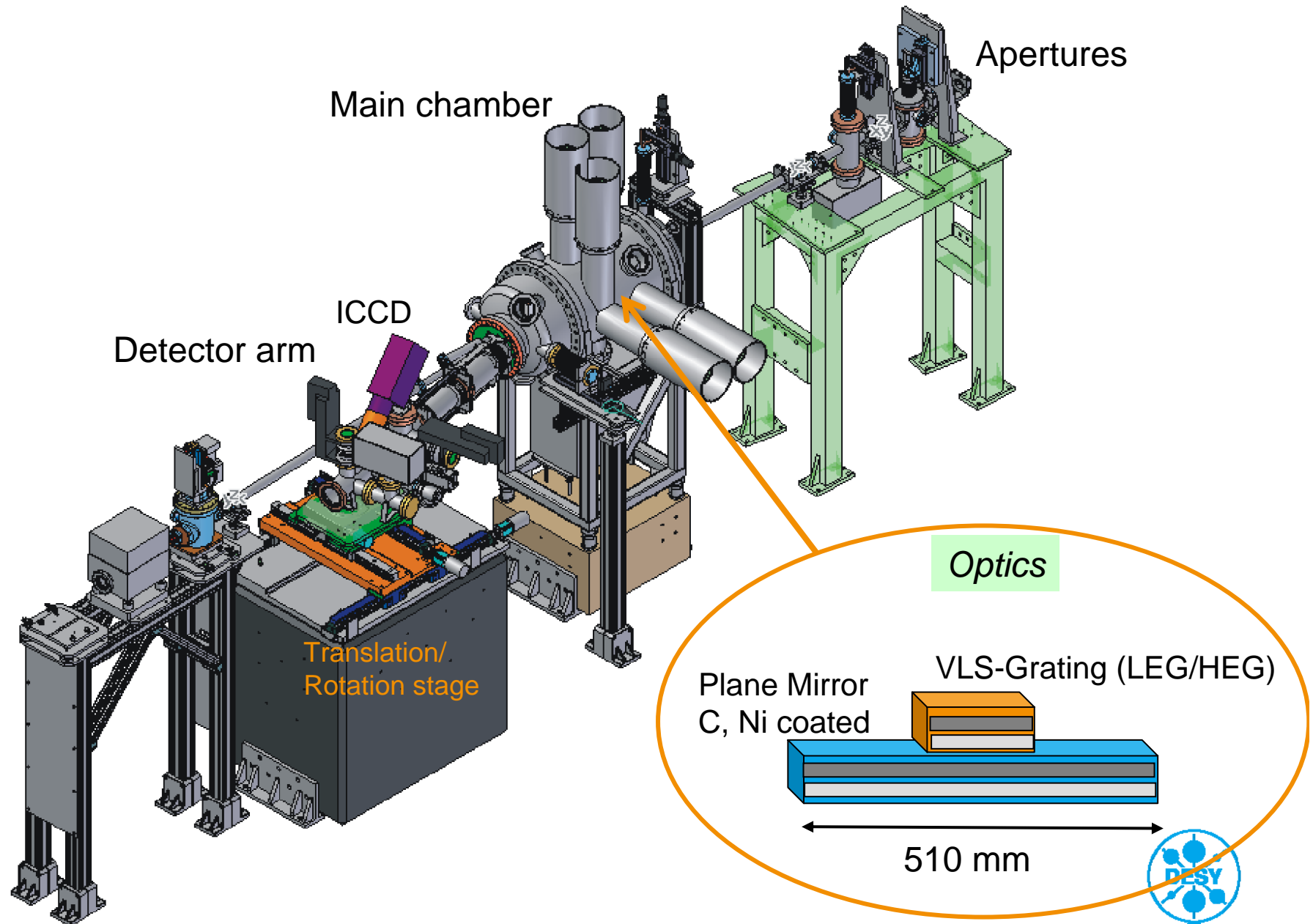

Design Parameters of the VLS Spectrometer

Gratings

	HEG	LEG
working wavelength	6 - 40nm	20 - 60nm
centre line spacing	900 l/mm	300 l/mm
efficiency for 1st order	8 - 0.5%	11 - 1.5%
focal lengths	2.0 - 1.78m	2.0 - 1.84m
diffraction angle	83.8° - 74.5°	83.5° - 79.0°
resolving power (on CCD)	>7000	>4000
incident angle	88°	88°
coating	C, Ni	C



Design Parameters of the VLS Spectrometer

Resolving power ($\lambda/\Delta\lambda$):

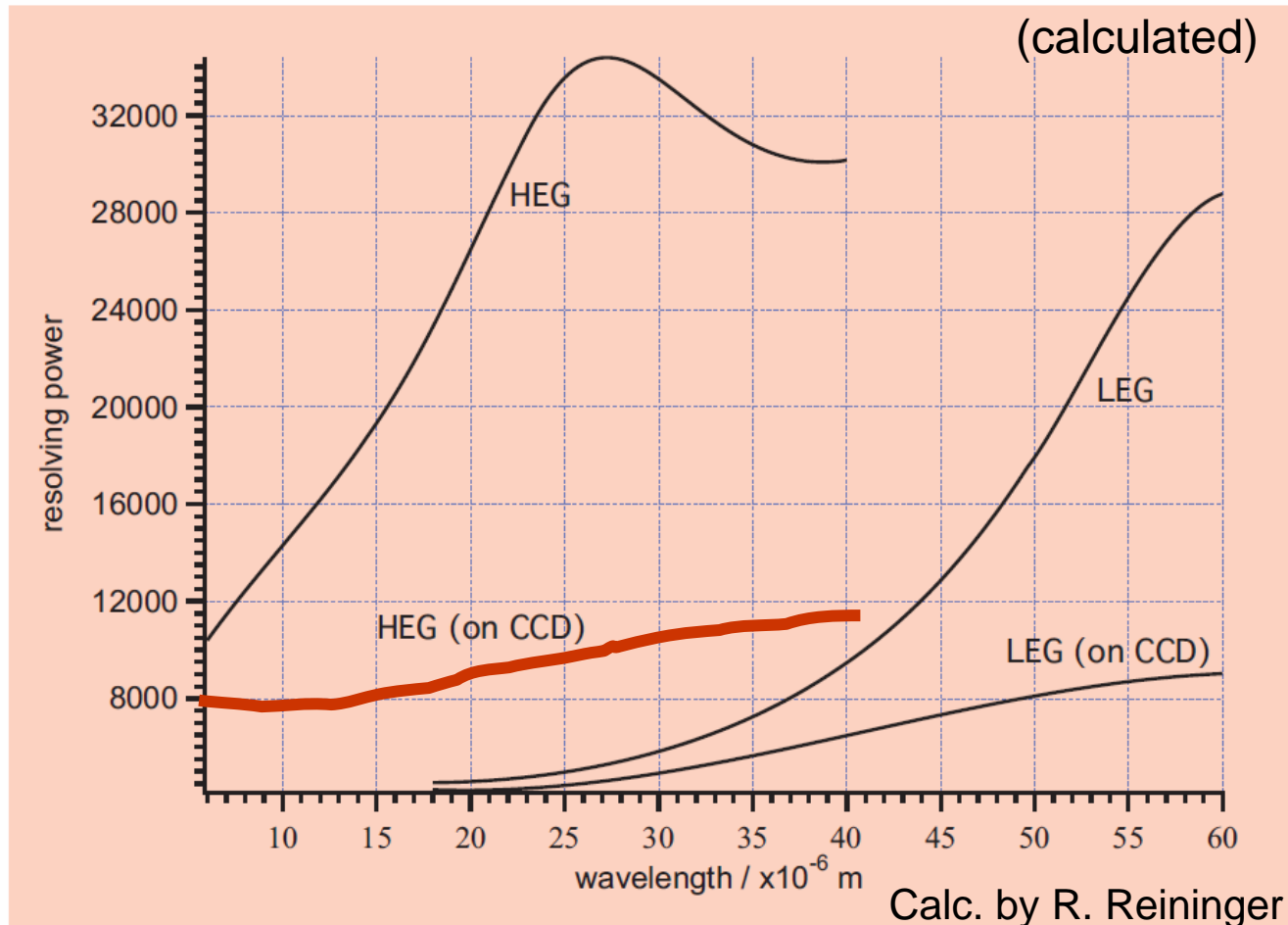

- Pixel size CCD-Detector: 20 microns
- Calculation based on measured and calculated FEL beam profiles



Design Parameters of the VLS Spectrometer

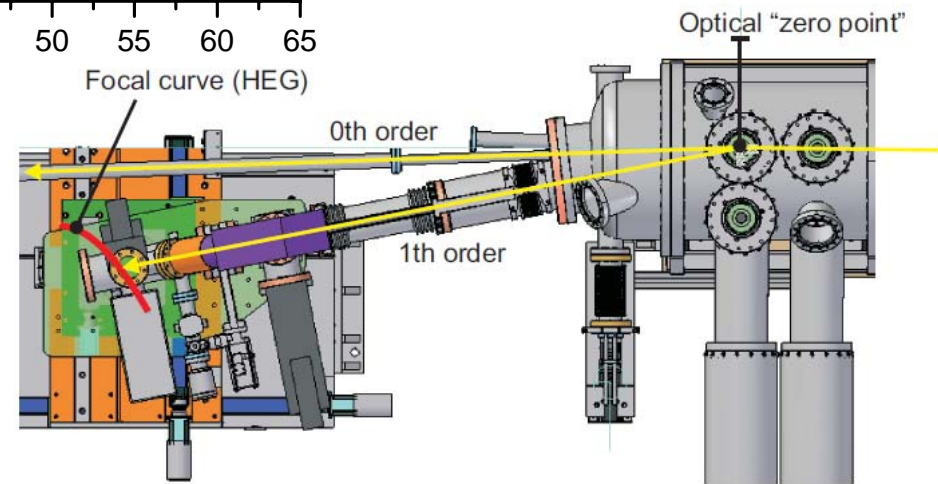
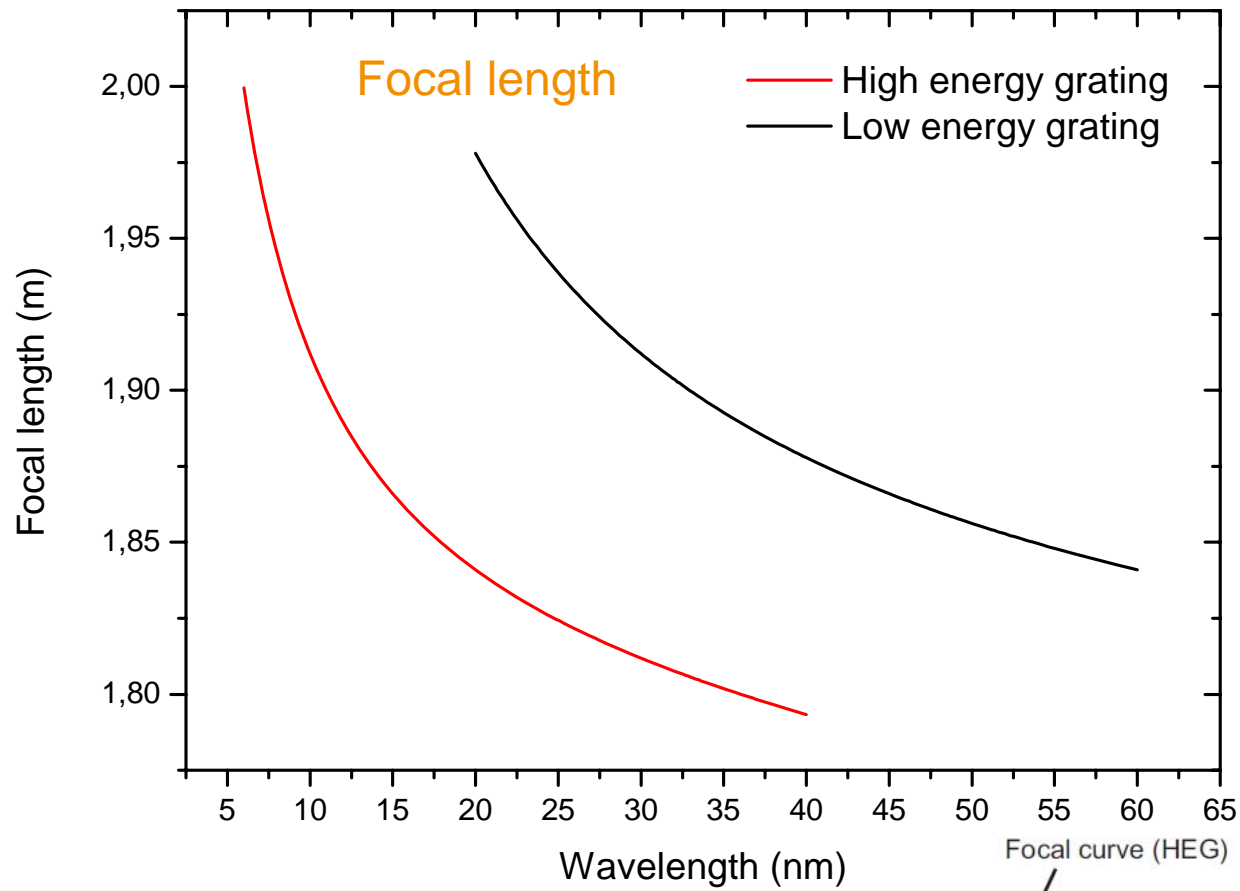

Inside the optics chamber

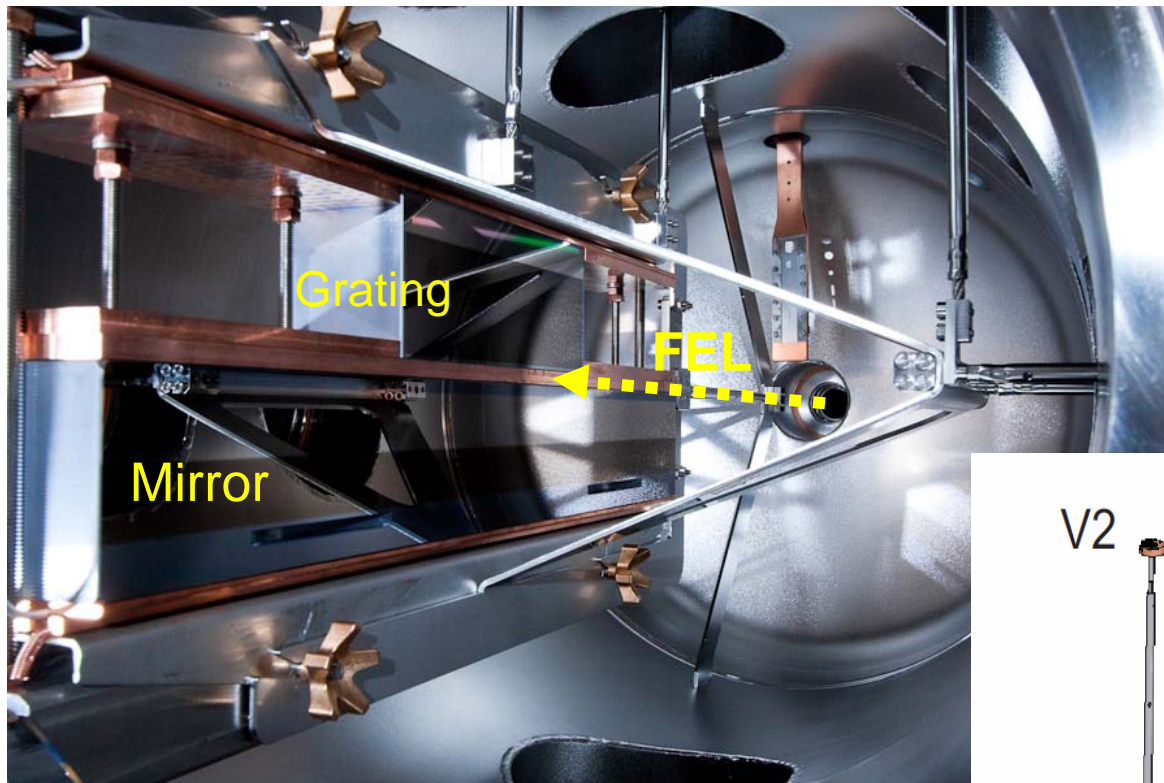

Switching between mirror & grating possible

- 6 rod bearing system
- Strong collaboration with Bessy/HZB
- Motorized alignment possible in 5 DOF

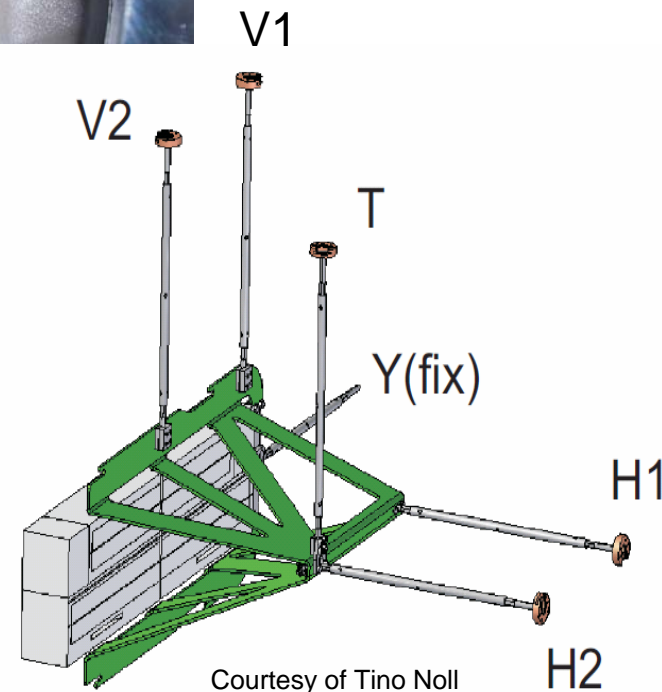

Optics mount (old design)

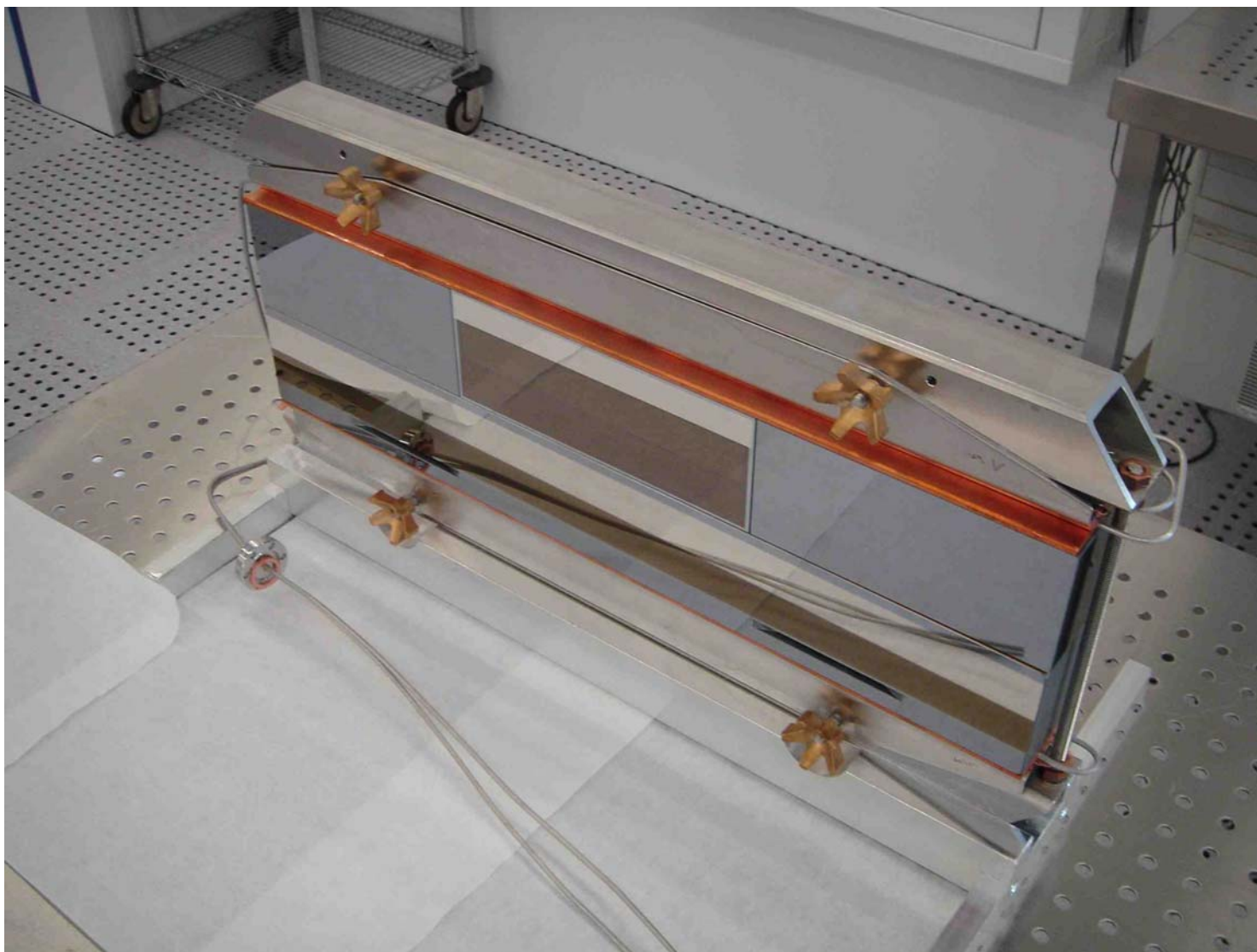

Height profile/slope errors (measured by F. Siewert@BESSY)

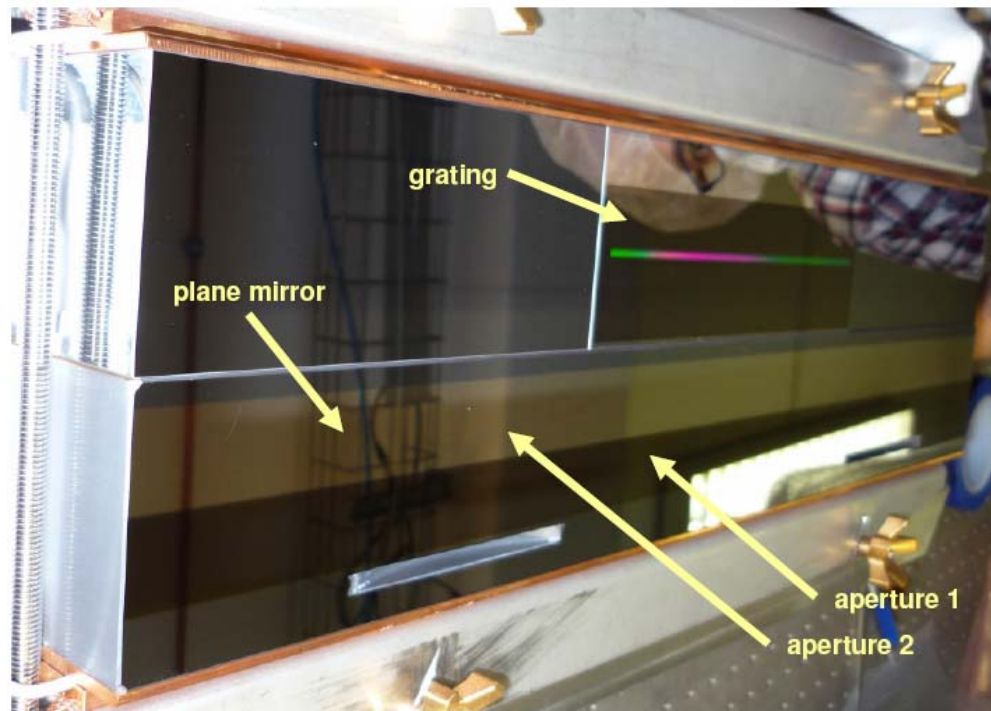

Initial holder design

Slope errors

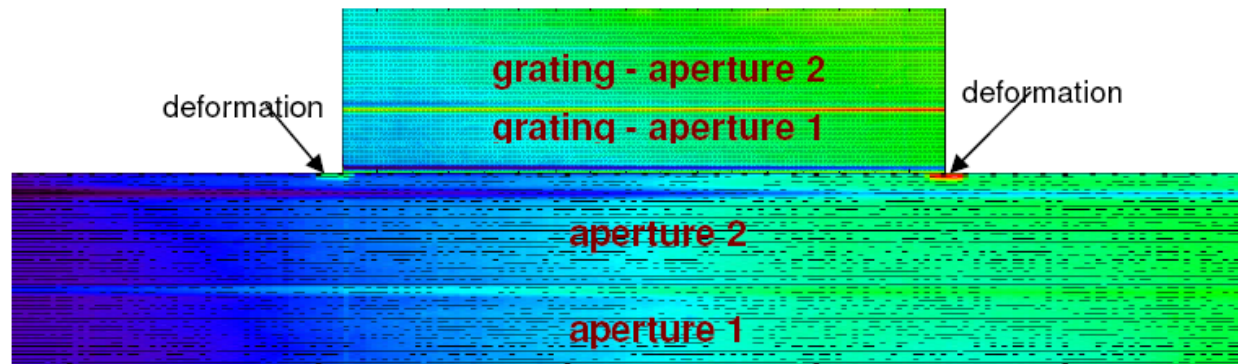

Measurement results of the new optics-holders

Redesigned optics mount

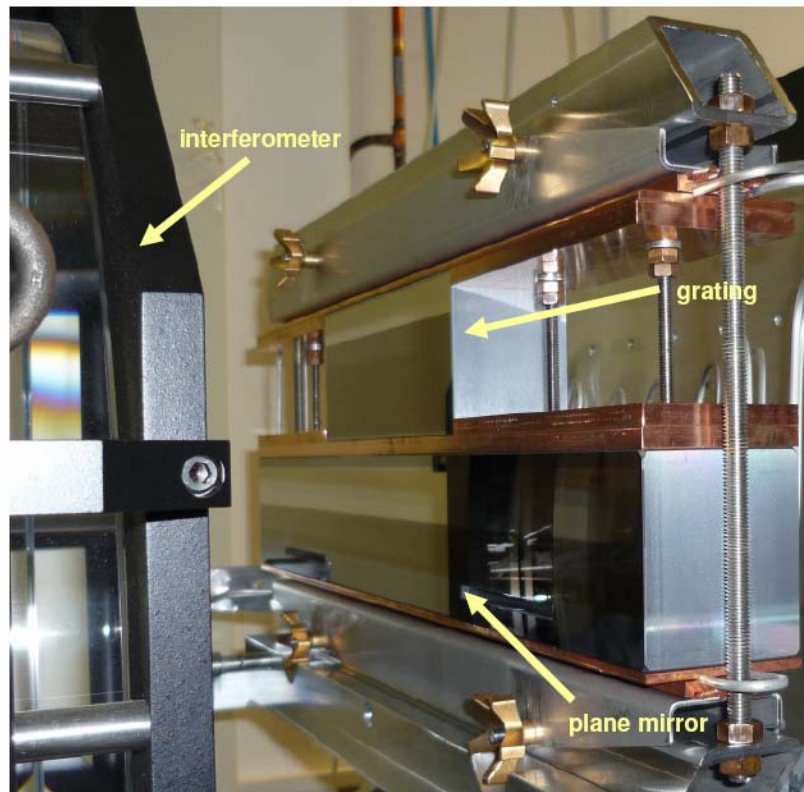

Courtesy of Frank Siewert

Height profile
measured at the 18" Zygo-Interferometer

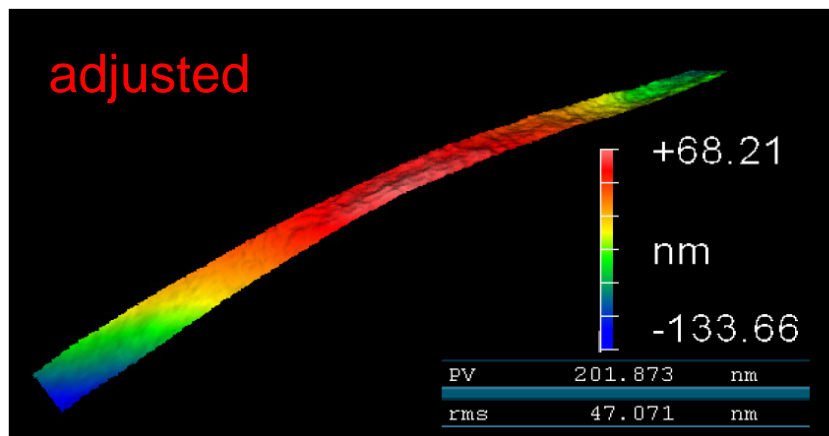
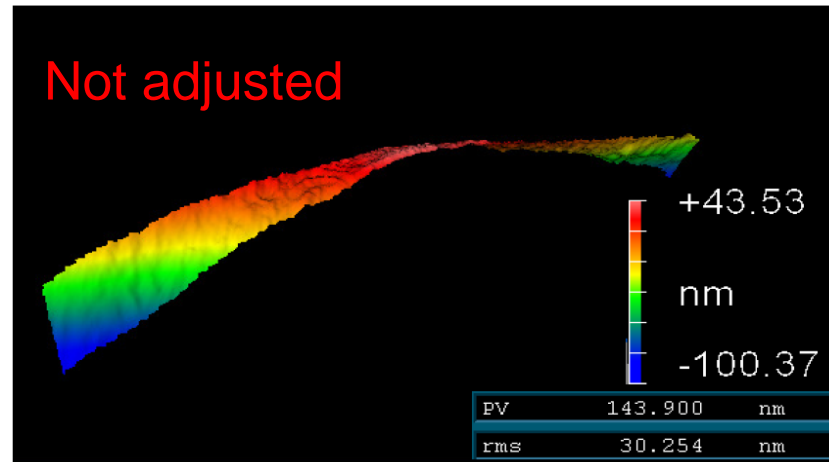

Optics mounted in chamber

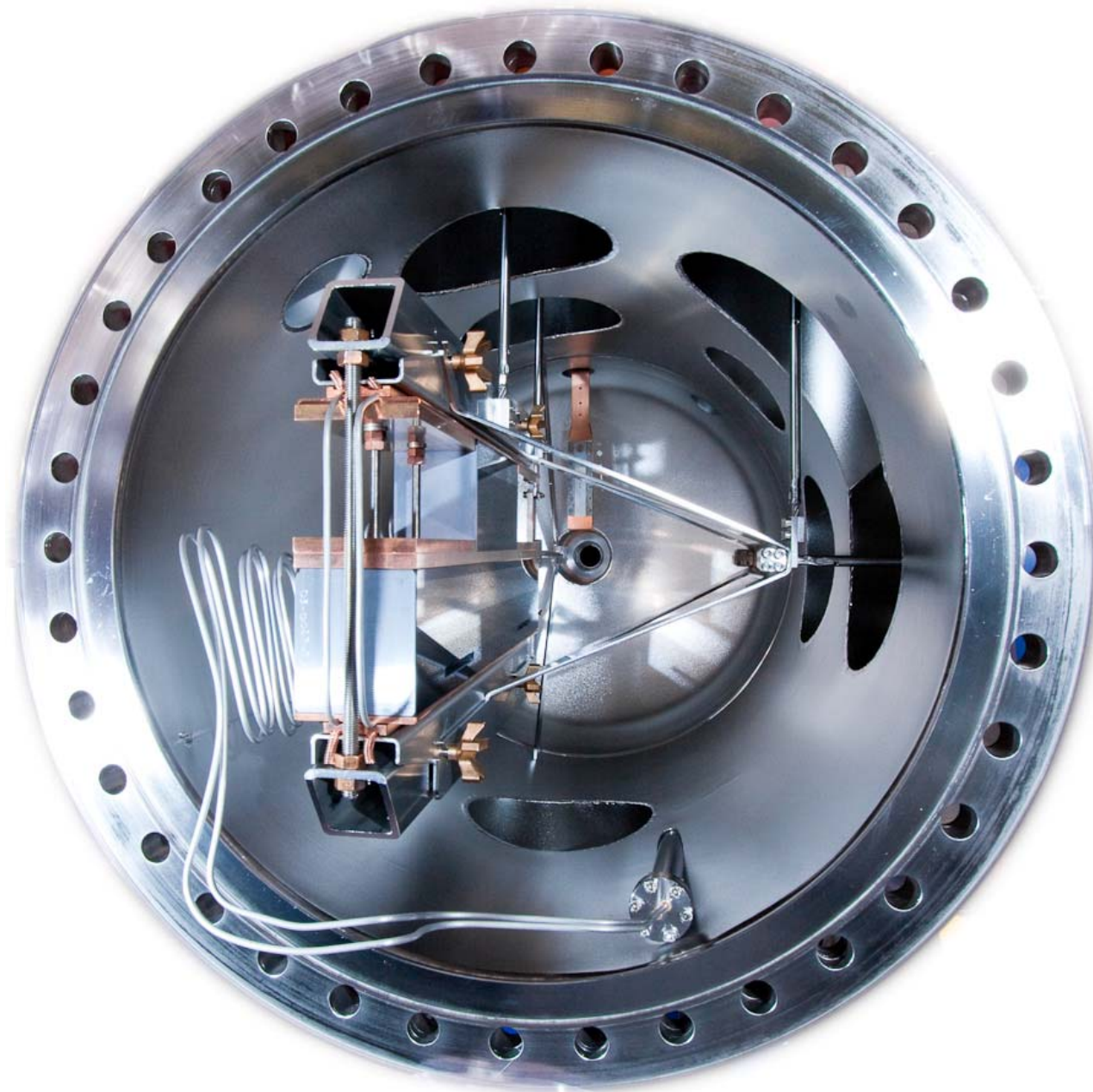

Detection features

Detection unit

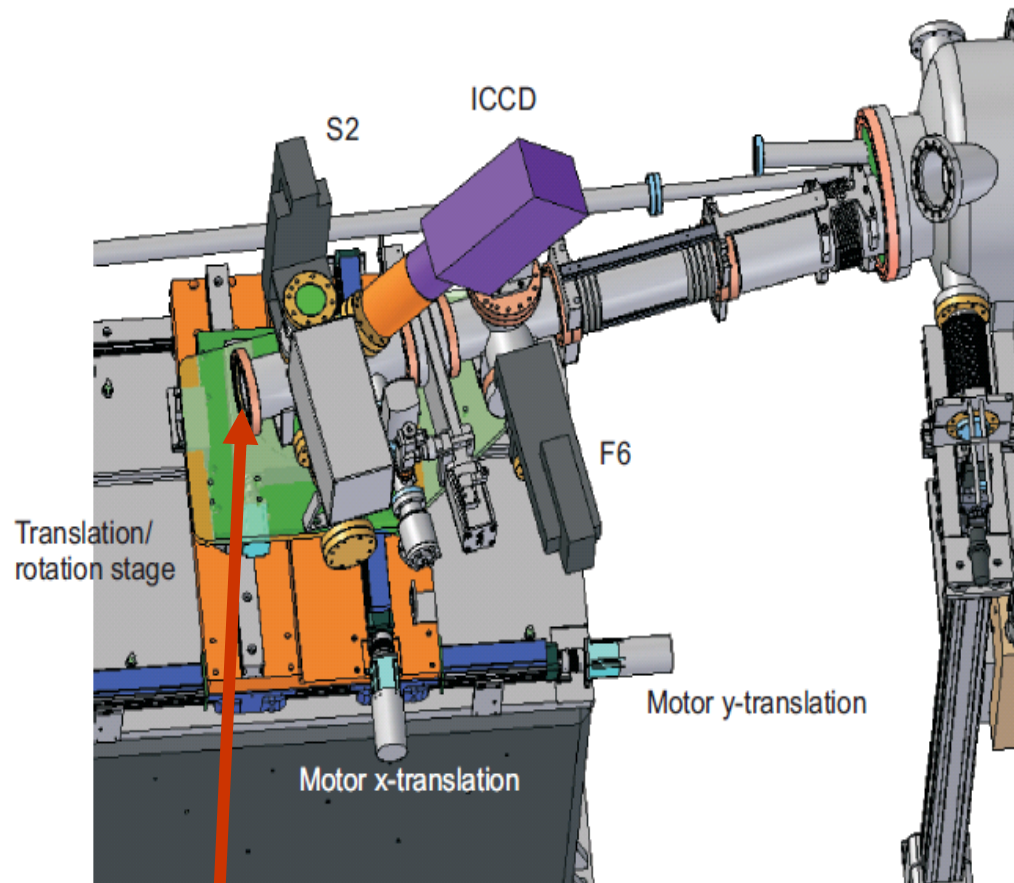

free port for 2nd detector system

- Ce:YAG screen + ICCD (1280 x 1024)
- Whole detection unit can be x- and y-translated
- Rotation of +/- 4° possible
- Single pulse detection possible (on pulse out of the pulse train)



What happend during the shutdown time?

An **open heart surgery!**

- > New (redesigned) motor driving system installed (major act!)
- > Redesign of optic mount & metrologie checks
- > Reinstallation of all components and extensive testing of the VLS motorized parts

Motors work very reliable !

**Tunnel alignment laser could
be sent over all BL-beamlines!**

Out of the valley of tears...?



What brings the Future ?

- > The World Cup title...(hopefully)
- > Commissioning of the spectrometer with FLASH-beam (first spectra!)
- > Calibration and performance checks (in August 2010)

Thanks for the attention



Properties of the mirror

Manufacturer: Carl Zeiss Laser Optics GmbH + DESY alignment set-up
 Customer: DESY
 Serial No.: 03-0037- BL0M1
 Size l x b x h [mm]: 510 x 60 x 70
 Optical aperture size [mm]: 490 x 20 (2 apertures)
 Substrate material: Si (coated on two stripes: C and Ni)

	Spezifikation	ZEISS - Messung	NOM - Messung (laterale Auflösung: $\approx 2,5 - 800$ mm)
Radius	$R > 20$ km	$R = 230$ km (measured face side)	$R = -164$ km (measured face up, free state at aperture 2) $R = +142$ km (mounted - aperture 1) $R = +228$ km (mounted - aperture 2)
Slope Error	0,1 arcsec rms (tangential)	0.07 arcsec rms (measured face side)	0.08 ± 0.015 arcsec rms (measured face up, free state at aperture 2) 0.25 ± 0.015 arcsec rms (mounted - aperture 2) 0.26 ± 0.015 arcsec rms (mounted - aperture 2)

Tabelle 1: Measurement results

(Note: 1arcsec = 4,848 μ rad)

