



TIME-PRESERVING MONOCHROMATORS FOR ULTRASHORT EXTREME-ULTRAVIOLET PULSES

Luca Poletto

**CNR - Institute of Photonics and Nanotechnologies
Laboratory for UV and X-Ray Optical Research
Padova, Italy**

e-mail: poletto@dei.unipd.it

Background: high-order harmonics generation

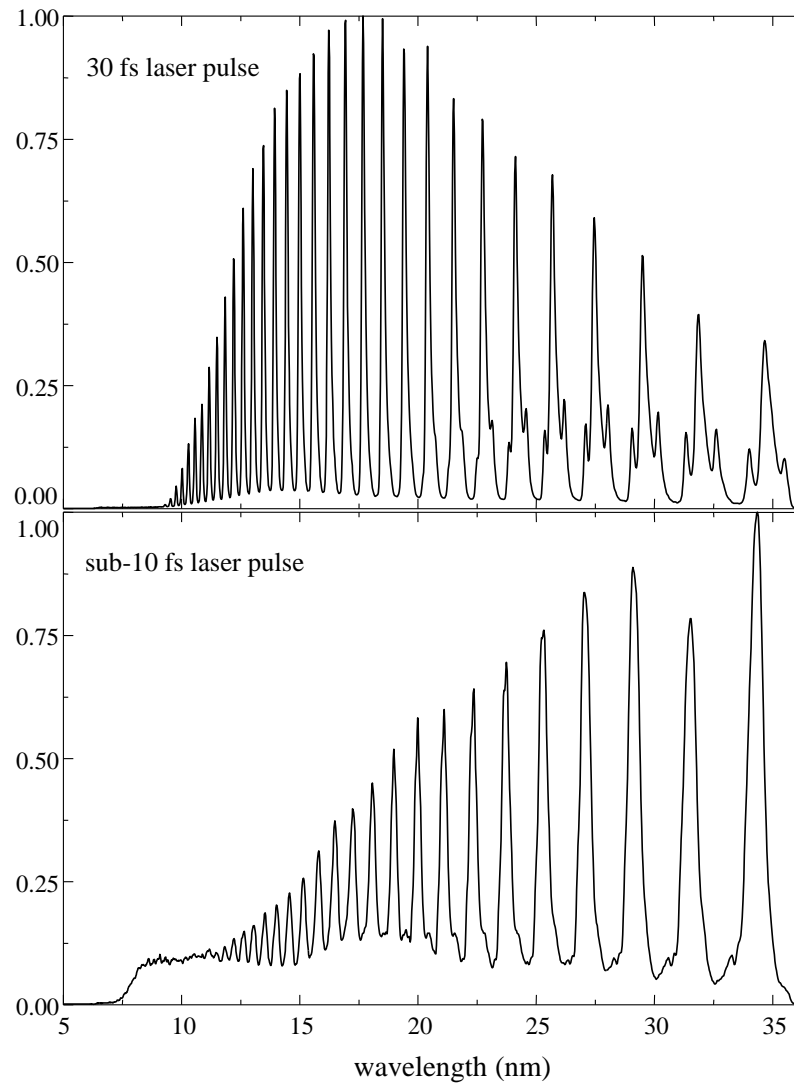

Outline

- HANDLING AND SPECTRAL SELECTION OF ULTRASHORT PULSES
- THE OFF-PLANE CONFIGURATION
- REALIZATION OF TIME-PRESERVING MONOCHROMATORS

High-order harmonics selection

Let us consider the problem of the extraction of a single harmonic within a broad spectrum to obtain an ultrafast XUV “monochromatic” pulse

⇒ EUV TUNABLE MONOCHROMATOR FOR HHs

THE MONOCHROMATOR HAS TO PRESERVE THE TEMPORAL DURATION OF THE EUV PULSE AS SHORT AS IN THE GENERATION PROCESS

This is crucial in order to have both HIGH TEMPORAL RESOLUTION and HIGH PEAK POWER

THE PROBLEM OF TIME PRESERVATION IS SIMILAR IN CASE OF THE SPECTRAL SELECTION OF FREE-ELECTRON-LASER PULSES

Femtosecond pulses

The **time broadening** of the pulse may be forced by a **FILTERING OF ITS SPECTRUM** operated by the optics

FOURIER LIMIT
$$\Delta\tau_{FWHM} = \frac{\lambda^2}{\Delta\lambda_{FWHM}} 1.5 \cdot 10^{-3}$$

Wavelength in nm
Time in fs

If the whole bandwidth of a single harmonics is selected, the spectral extension is maintained.

The same case applies to a FEL in case of a low-resolution monochromator used as a spectral filter (e.g. suppression of the background or selection of the FEL harmonics)

Single-grating monochromator

The wavelength selection is operated by a diffraction grating. The optical path of a ray differs from that of the neighbor by the quantity $\delta_{OP} = m\lambda$, where m is the diffraction order. The total difference, between the path on first to last groove is

$$\Delta_{OP} = Nm\lambda$$

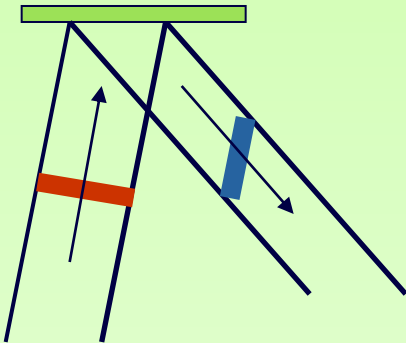

Es: 5-mm FWHM beam, $\lambda=30$ nm (41 eV), 300 gr/mm grating, normal incidence

\Rightarrow 1500 illuminated grooves

\Rightarrow path-difference $\Delta OP_{FWHM} = 45 \mu\text{m}$, $\Delta t_{FWHM} = 150$ fs

Limit of the grating monochromator

For a given resolution $\lambda/\Delta\lambda$, the minimum number of illuminated grooves (first diffracted order) is $N = \lambda/\Delta\lambda$ (Rayleigh criterion).

This gives a broadening on the focus that is \approx equal to the Fourier limit.

$$\Delta\tau_{FWHM} = \frac{\lambda^2}{\Delta\lambda_{FWHM}} 1.7 \cdot 10^{-3}$$

If the number of grooves that are illuminated is the minimum for a given resolution, the broadening given by a diffraction grating is comparable to the Fourier limit.

OPERATION AT GRAZING INCIDENCE !

When working with gratings at grazing incidence, the illuminated area is long and the number of illuminated grooves is normally far superior to the Rayleigh limit.

The problem of time preservation has to be analyzed !

Design of single-grating monochromators

Aim of the design is to keep the number of illuminated grooves as close as possible to the resolution $\lambda/\Delta\lambda$

For a grating used in the classical diffraction scheme, the effective groove density as seen by the beam is increased by the factor $1/\cos\alpha$

E.g., for $\alpha = 85^\circ$, $1/\cos\alpha \approx 11$

The groove density and the corresponding blaze profile that are required to maintain very low temporal broadening (few to several tens of femtoseconds) is unfeasible

- The classical diffraction scheme can be used to make the spectral selection with a single grating
- The temporal broadening is in the range 100-200 fs FWHM for technically feasible monochromators
- The efficiency is limited by the quality of the grating surface ($\approx 20\%$)

Double-grating design

Scheme for path length equalization: the mechanism which originates the path difference must be canceled.

- equalization of path length for diverse spectral components
- combination of two diffractive elements in negative dispersion
- correction of the optical aberrations

DRAWBACKS OF THE DOUBLE-GRATING DESIGN

- **LOW EFFICIENCY** (two gratings)
- **DESIGN NOT SUITABLE FOR BROAD-BAND MONOCHROMATORS AT GRAZING INCIDENCE**

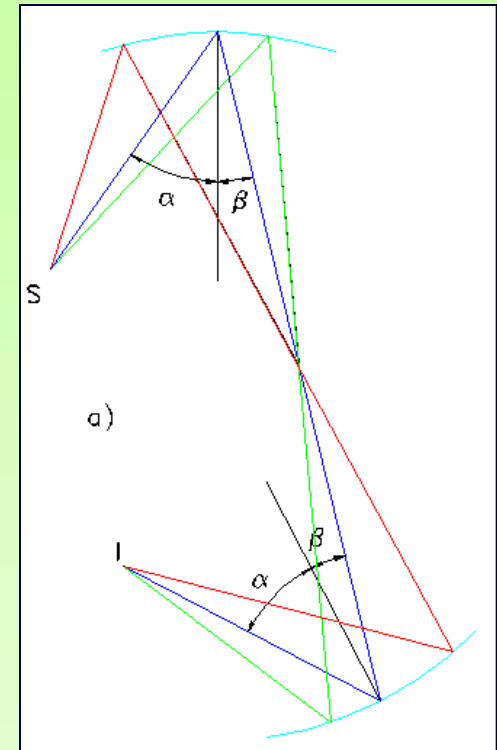

P. Villoresi, Appl. Opt. **38**, 6040 (1999)

Conclusions: spectral selection of ultrashort pulses

- The spectral selection of XUV ultrashort pulses made by diffraction gratings may introduce a severe temporal broadening
- Single-grating monochromators with ≈ 100 fs resolution are used in HH beamlines
- Time-preserving configurations have to be realized with double-grating designs: difficult at grazing incidence

Outline

- HANDLING AND SPECTRAL SELECTION OF ULTRASHORT PULSES
- THE OFF-PLANE CONFIGURATION
- REALIZATION OF TIME-PRESERVING MONOCHROMATORS

The off-plane mount

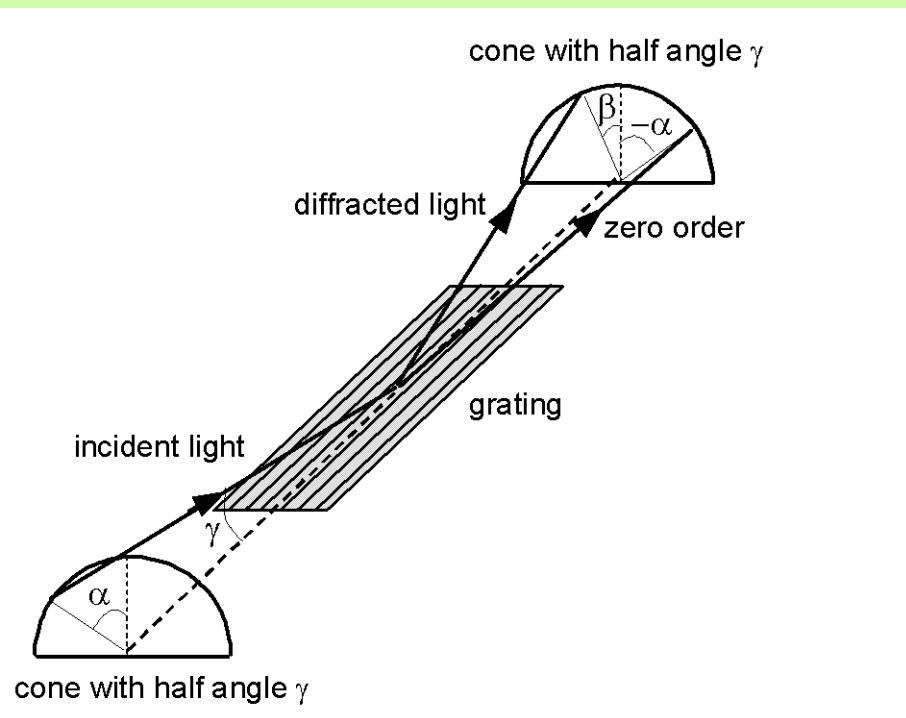

OFF-PLANE MOUNT \Rightarrow the incident and diffracted wave vectors are almost parallel to the grooves

Monocromators in the off-plane mount

Entrance slit

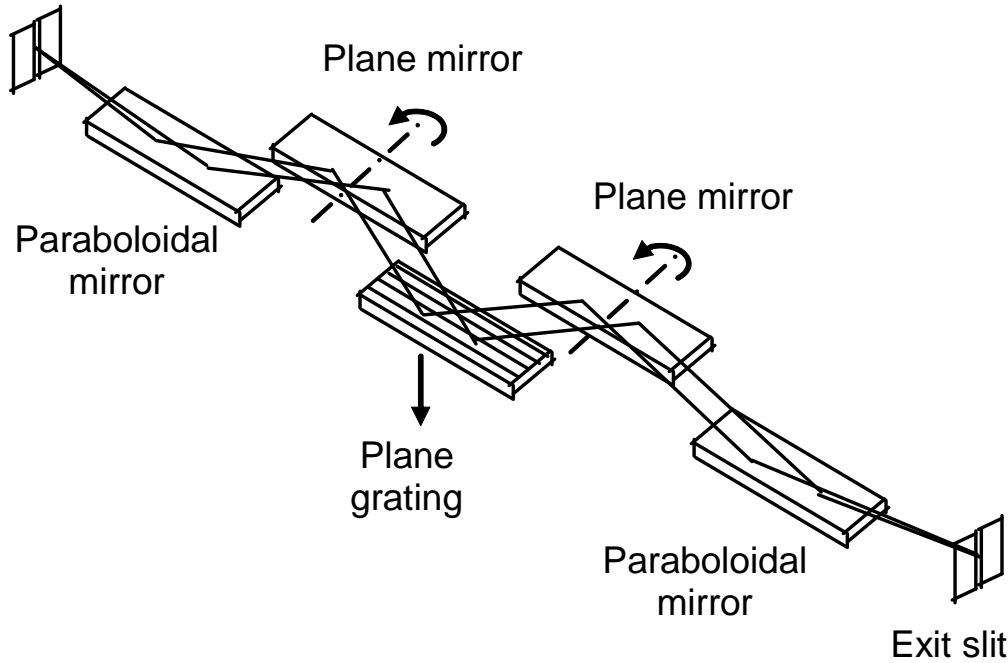

Entrance slit

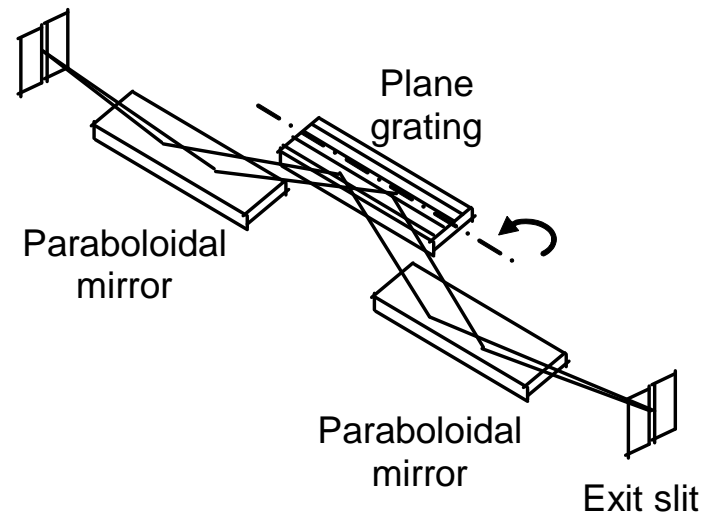

Efficiency of gratings for XUV monochromators

Grating #1

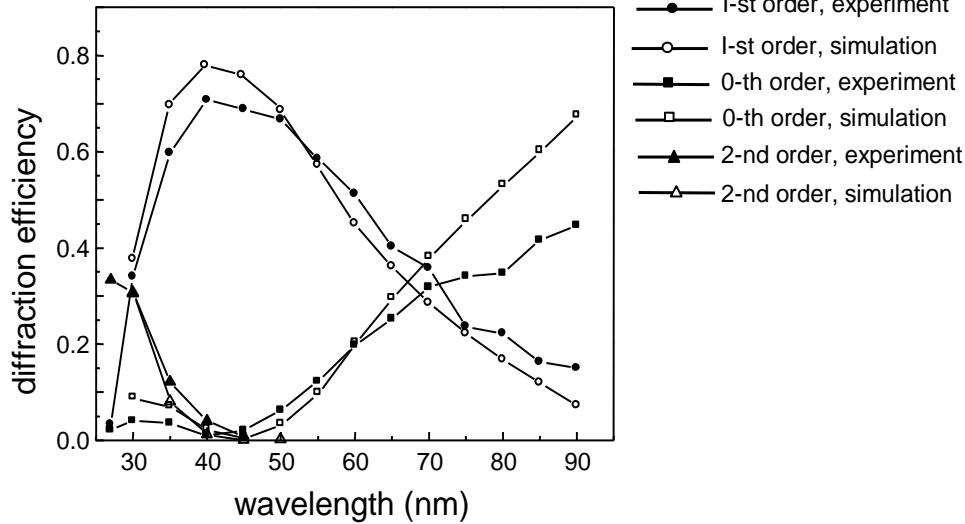

Grating #2

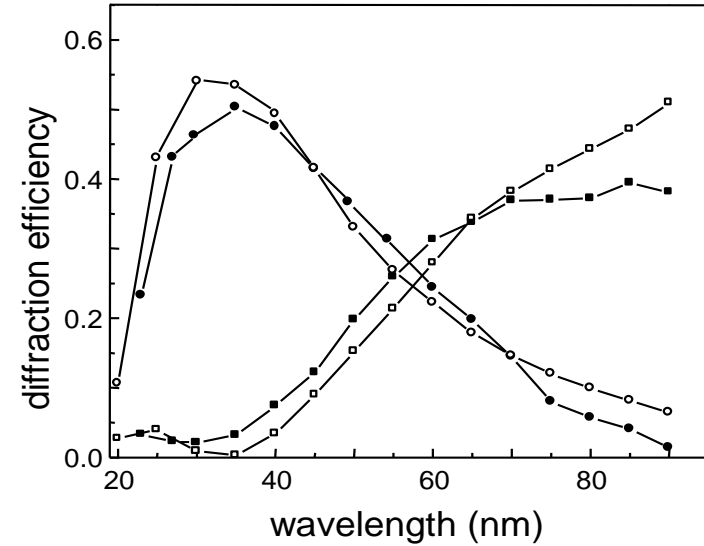

Grating #3

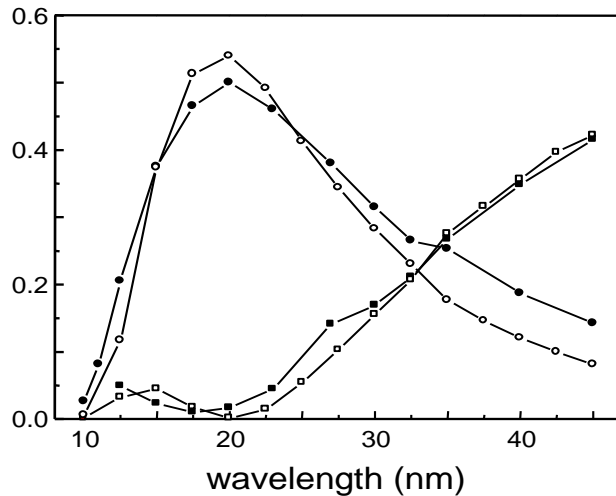

Grating	gr/mm	blaze angle	altitude angle	blaze wavelength	Wavelength region
1	400	9.7°	3°	44 nm	20-90 nm
2	400	4.5°	5.6°	38 nm	20-90 nm
3	600	7°	3°	21 nm	10-45 nm

Classical design vs off-plane

Wavelength 30 nm
Beam size 1 mm half-width

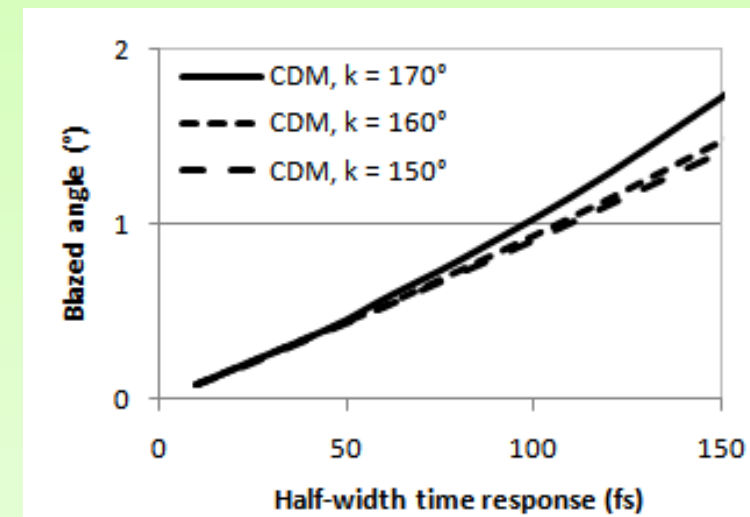
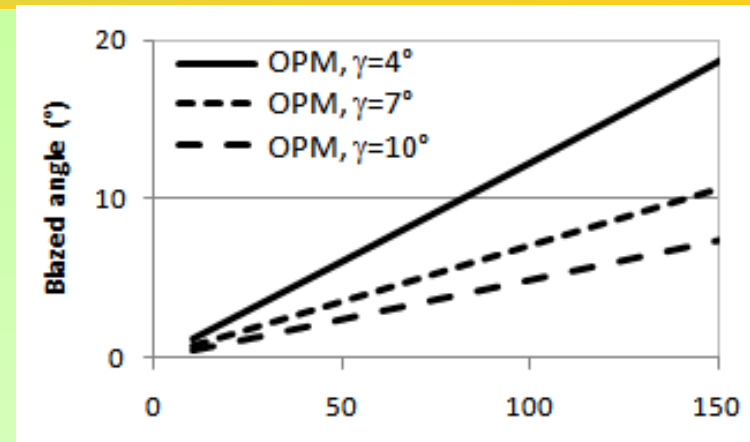
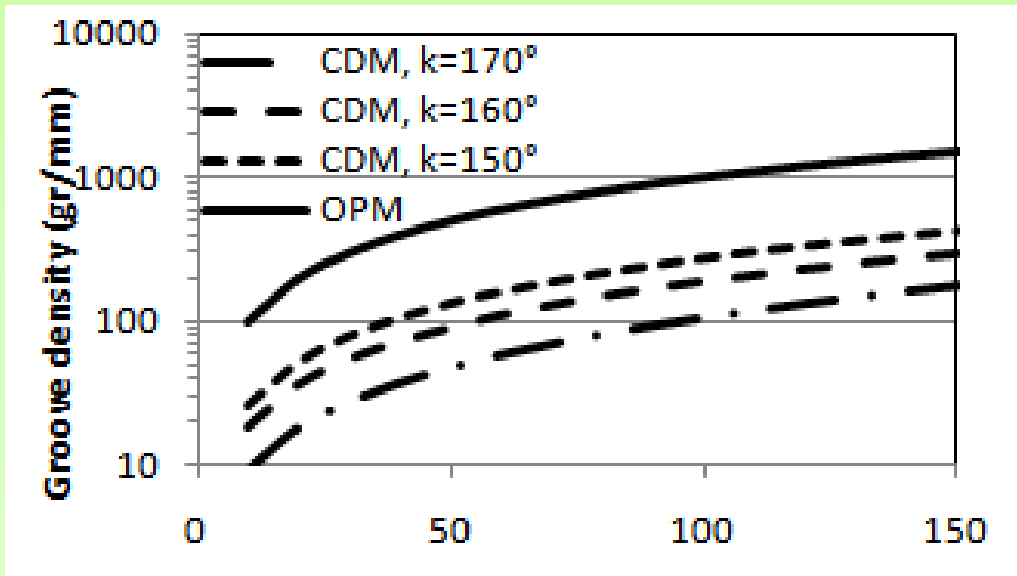

The off-plane mount should be used for time responses in the 10-100 fs range.
The classical mount is suitable for time responses in the 100-200 fs range.

Single-grating monochromators in the off-plane mount

The groove density that is required to maintain very low temporal broadening is feasible with high efficiency

$\lambda=30$ nm (41 eV), resolution 2%, 2 mrad FWHM divergence

Monochromator parameters: $\rho = 300$ mm, $\gamma = 4^\circ$

Grating: 200 gr/mm, $\alpha = 2.5^\circ$

Time duration at the output: 12 fs FWHM

Grating blaze angle: 2.5°

⇒ High efficiency is expected

Conclusions: the off-plane design

- The off-plane mount gives generally higher efficiency than the classical mount
- Single-grating monochromators with very low temporal broadening and high efficiency can be designed
- Double-grating grazing-incidence designs can be used

L. Poletto, P. Villoresi, F. Frassetto, **Diffraction gratings for the selection of ultrashort pulses in the extreme-ultraviolet**, in "Advances in Solid-State Lasers: Development and Applications", M. Grishin ed., INTECH (Croazia), <http://sciyo.com/books/show/title/advances-in-solid-state-lasers-development-and-applications> (2010)

Outline

- HANDLING AND SPECTRAL SELECTION OF ULTRASHORT PULSES
- OFF-PLANE CONFIGURATION
- REALIZATION OF TIME-PRESERVING MONOCHROMATORS

Case 1: single-grating monochromator

- Toroidal mirror to collimate the light from the entrance slit
- Plane grating in the off-plane mount
- Toroidal mirror to focus the light on the exit slit
- Grating rotation to perform the spectral selection

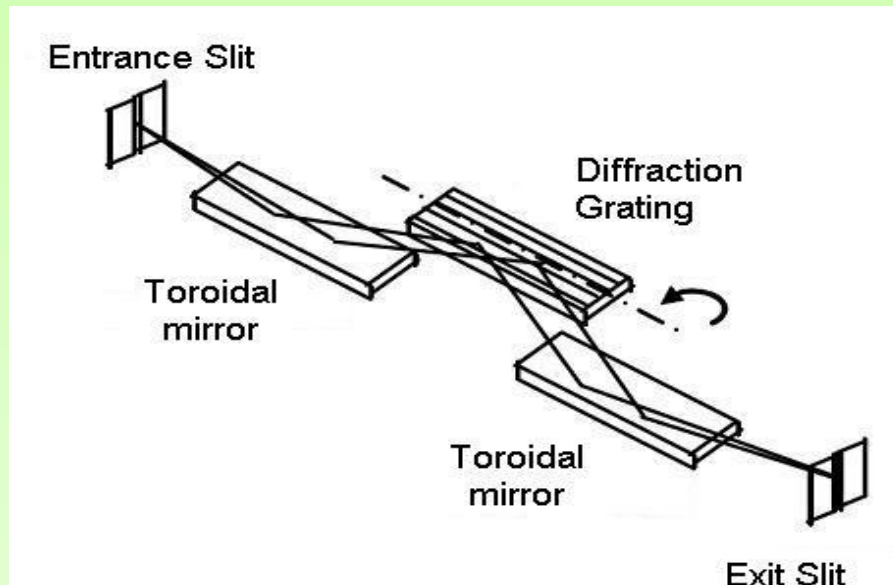

The ARTEMIS facility @Rutherford Lab (UK)

Three femtosecond synchronised laser beams

1. 14 mJ, 30 fs, 1-3 kHz CEP-stabilised
2. <10fs 800nm pulses
3. 30 fs, tuneable UV to mid-IR

Two femtosecond XUV beamlines

1. Broadband 10-100 eV XUV
2. Monochromatic short pulse (10-50 fs)

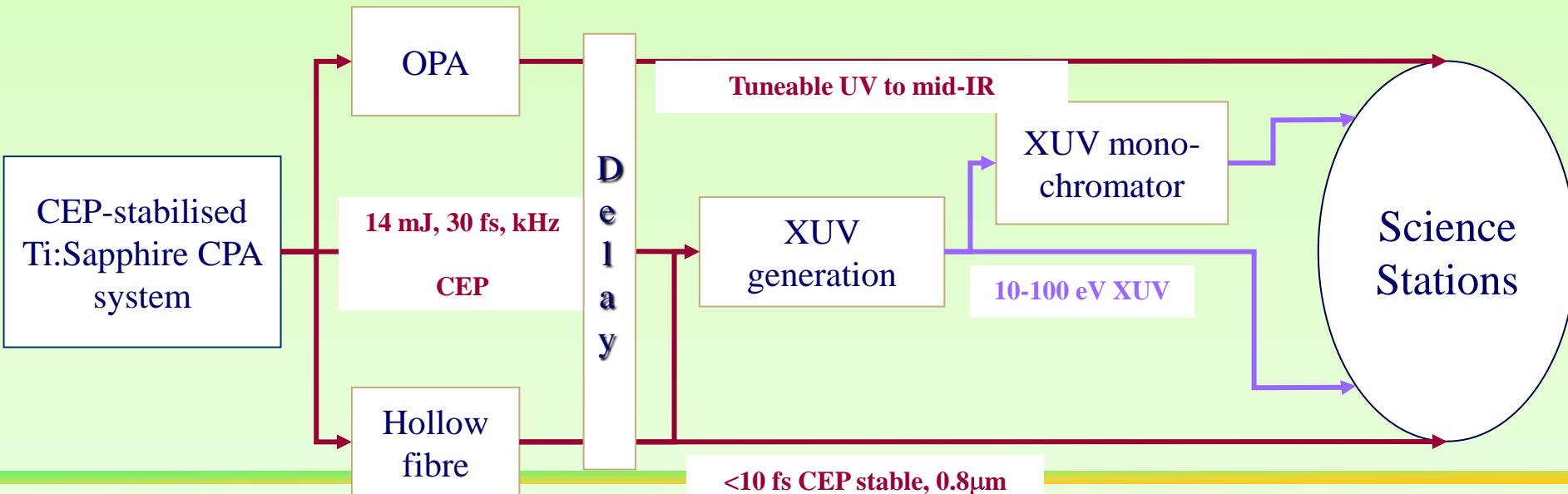

Facility Layout

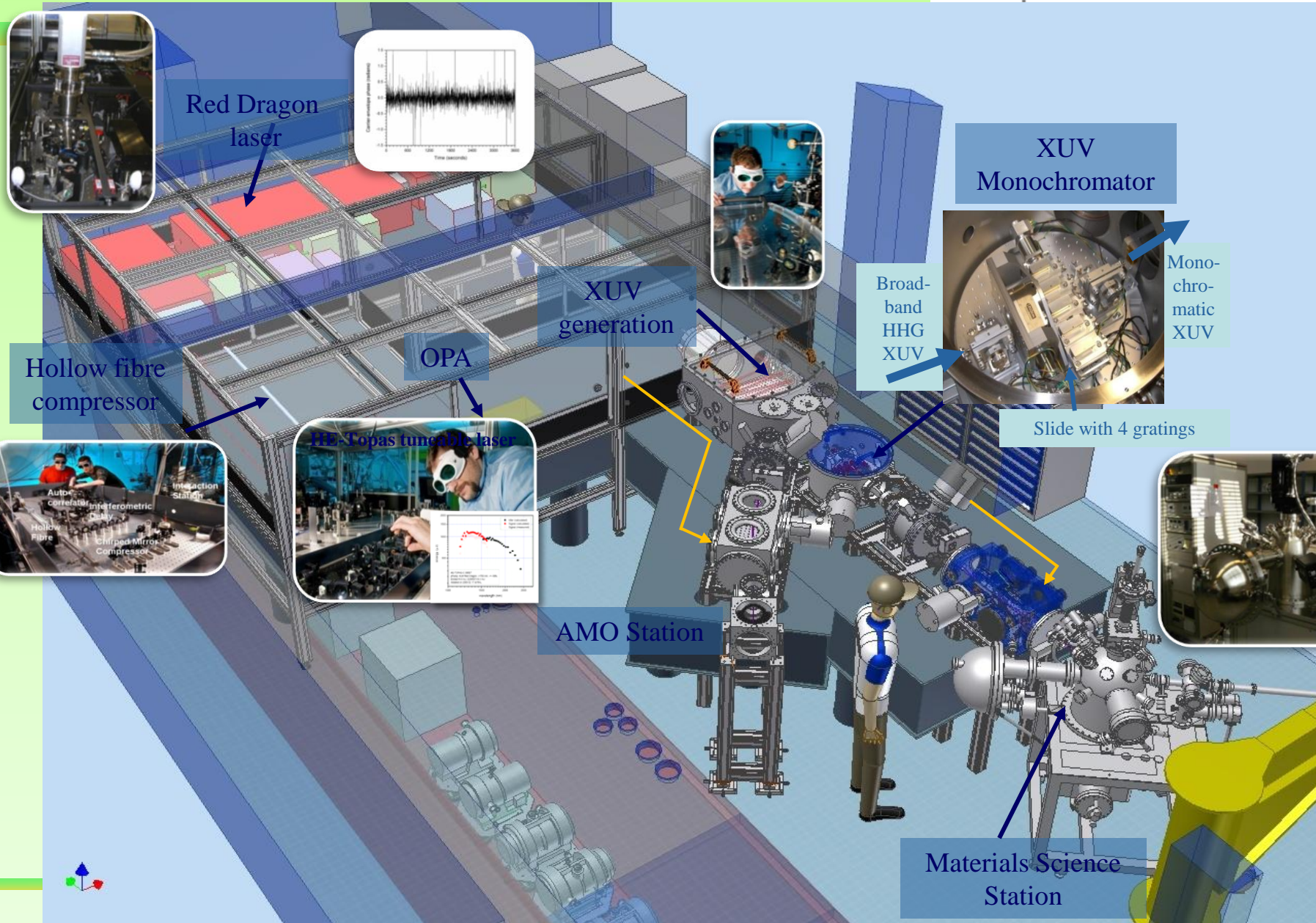

The XUV monochromator of ARTEMIS

Laboratory for
UV and X-ray
Optical Research



- Tunable in the 12 eV-100 eV range
- Four plane gratings in the off-plane mount
- Low resolution gratings: pulse duration ~ 10 fs
- High resolution gratings: pulse duration ~ 50 fs
- High efficiency: 25% peak efficiency measured

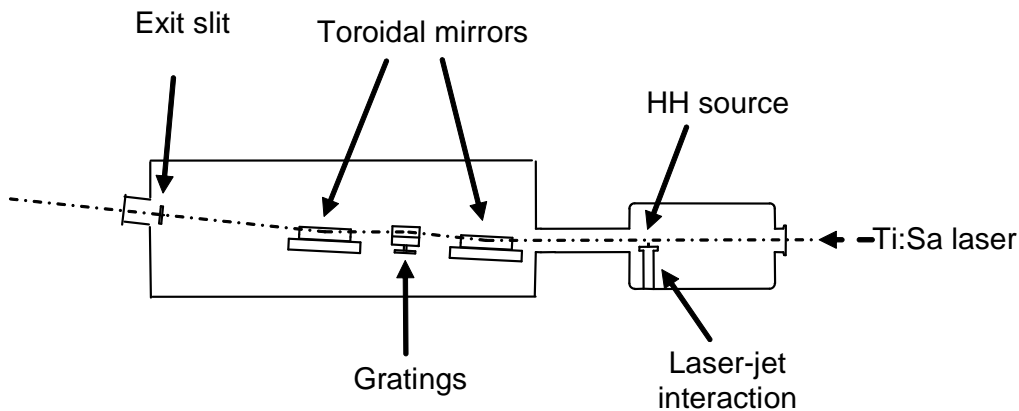
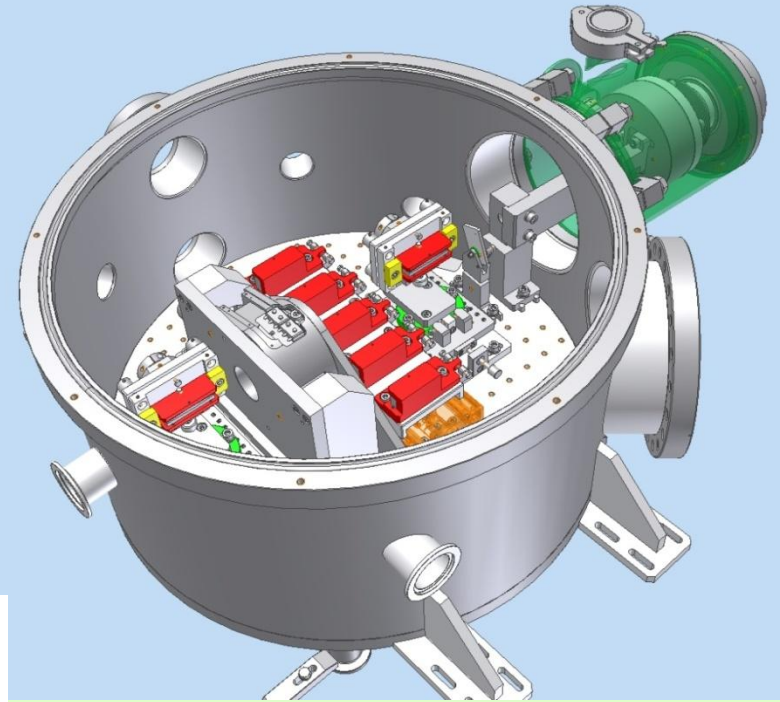

Pictures

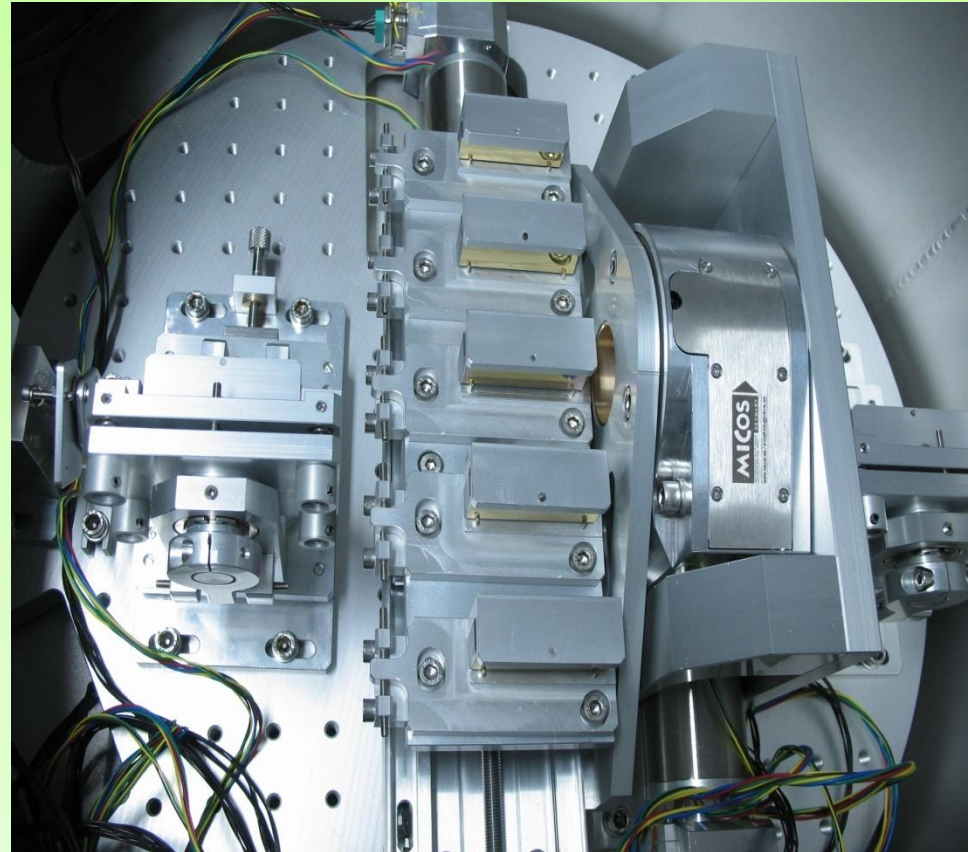
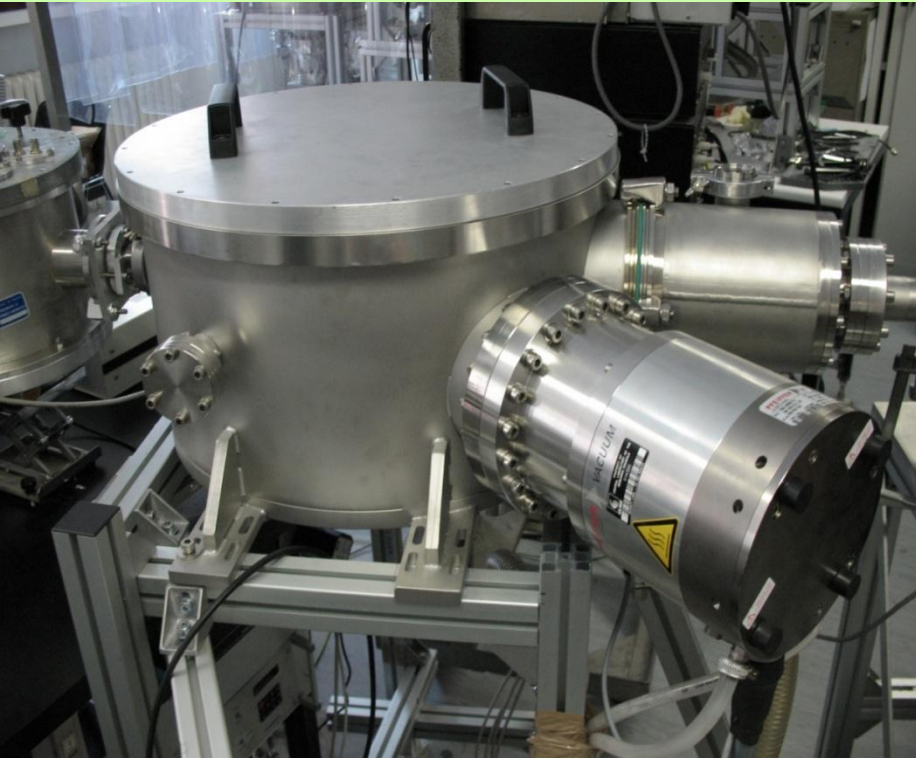

XUV Beamline: fsec Resolution

30fs, IR-
Laser
splitter

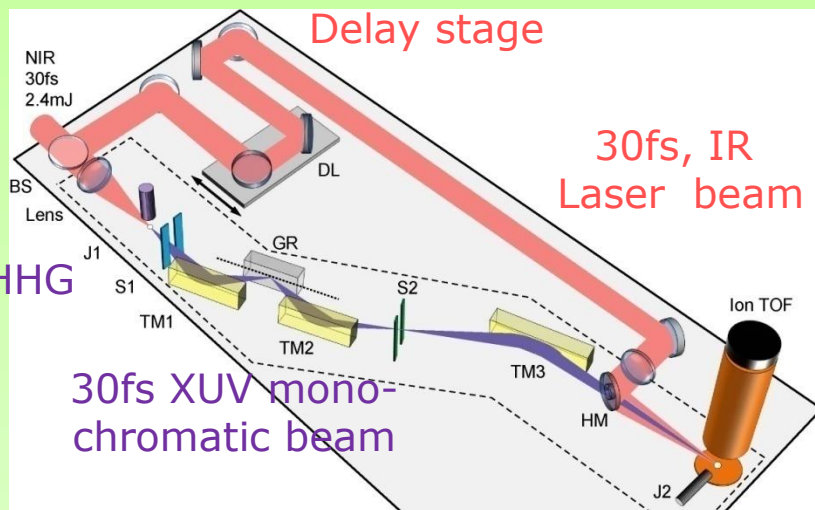

30fs XUV+IR focused on
Kr atoms in ToF spectrometer

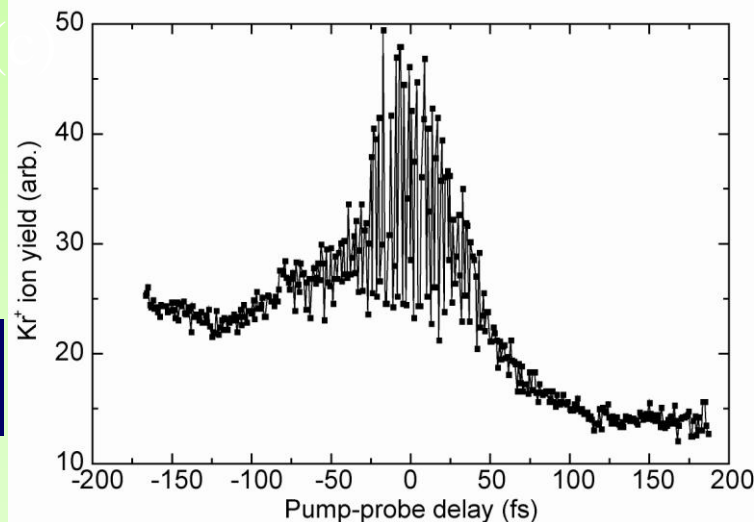
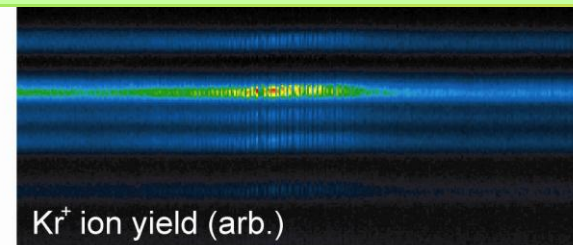

(a) <0.6fs Resolution Interferometer XUV + IR

XUV-Pump + IR-Probe: Kr^{2+} ion yield function of temporal delay XUV vs. IR

(b) XUV pulse duration measured $\sim 30\text{fs}$: XUV H23 ($E=35.7\text{eV}$) + IR ($E=1.55\text{eV}$).

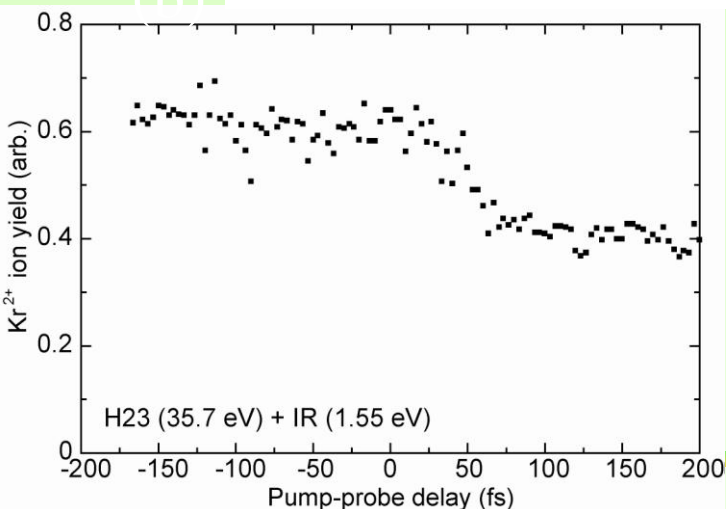

Case 2: double-grating monochromator (1)

DOUBLE-GRATING CONFIGURATION

The two gratings are mounted in **COMPENSATED CONFIGURATION** and **SUBTRACTIVE DISPERSION**.

Time compensation

- 1) the differences in the path lengths of rays with the same wavelength that are caused by the first grating are compensated by the second grating
- 2) rays with different wavelengths within the spectrum of the pulse to be selected are focused on the same point

Focusing

The focusing is provided by the toroidal mirrors

Spectral selection

A slit placed on the intermediate focus carries out the spectral selection of the HHs

Wavelength scanning

The wavelength scanning is performed by rotating the gratings around an axis tangent to the surface and parallel to the grooves

Case 2: double-grating monochromator (2)

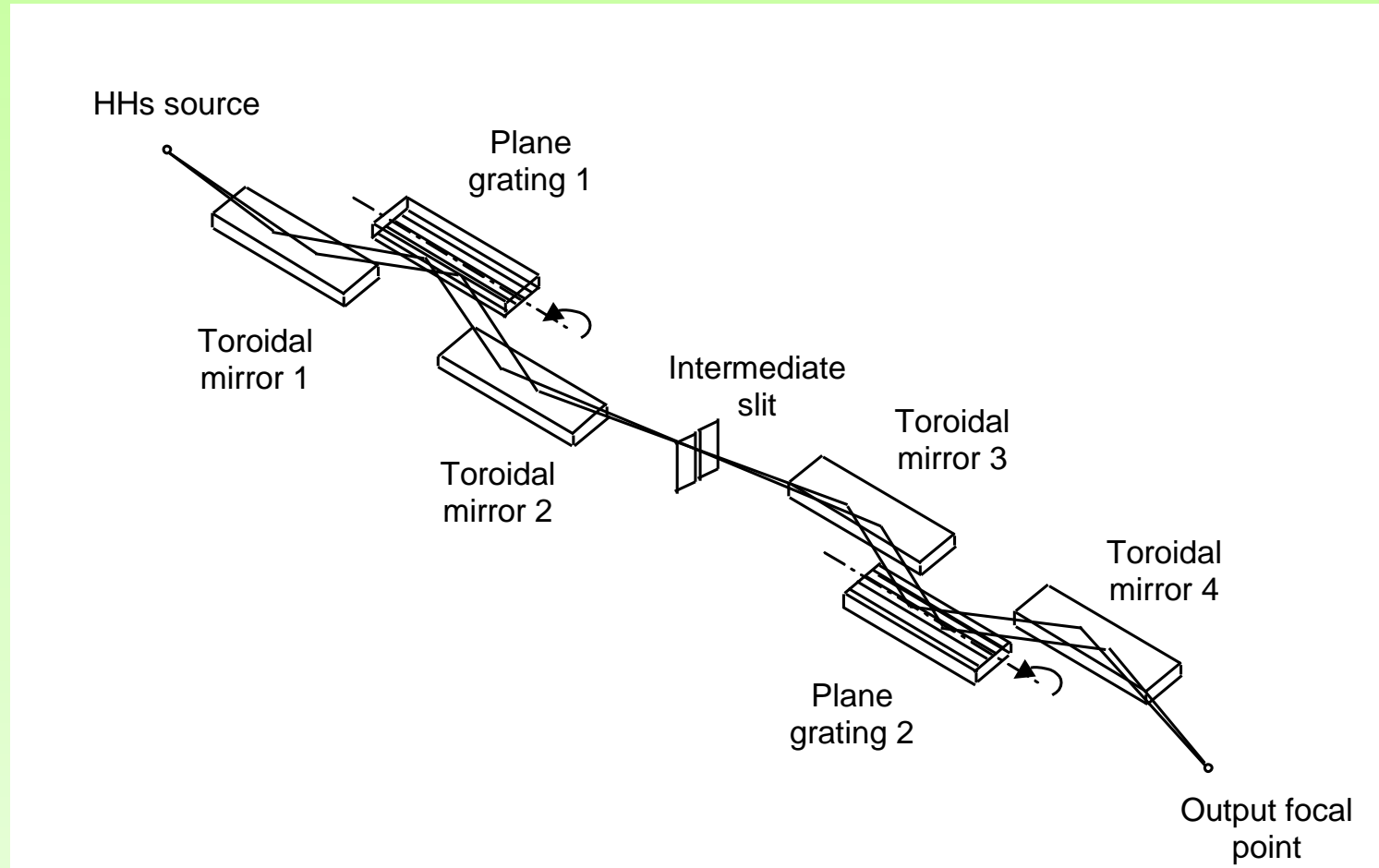

L. Poletto, *Appl. Phys. B* **78**, 1013 (2004)

L. Poletto and P. Villoresi, *Appl. Opt.* **45**, 8577 (2006)

L. Poletto, *Appl. Opt.* **48**, 4526 (2009)

The monochromator for the HH experiment in Milano

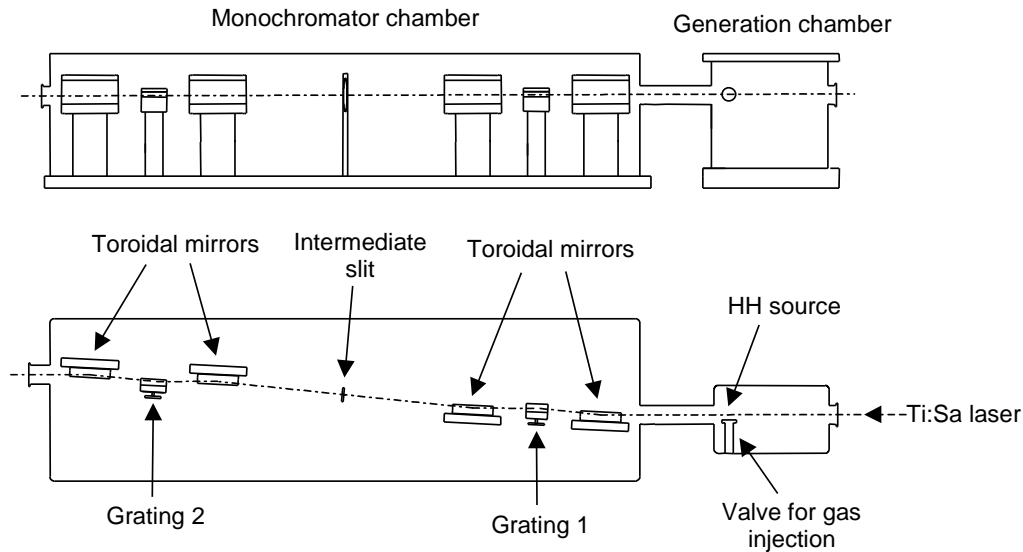

20-60 nm tunability

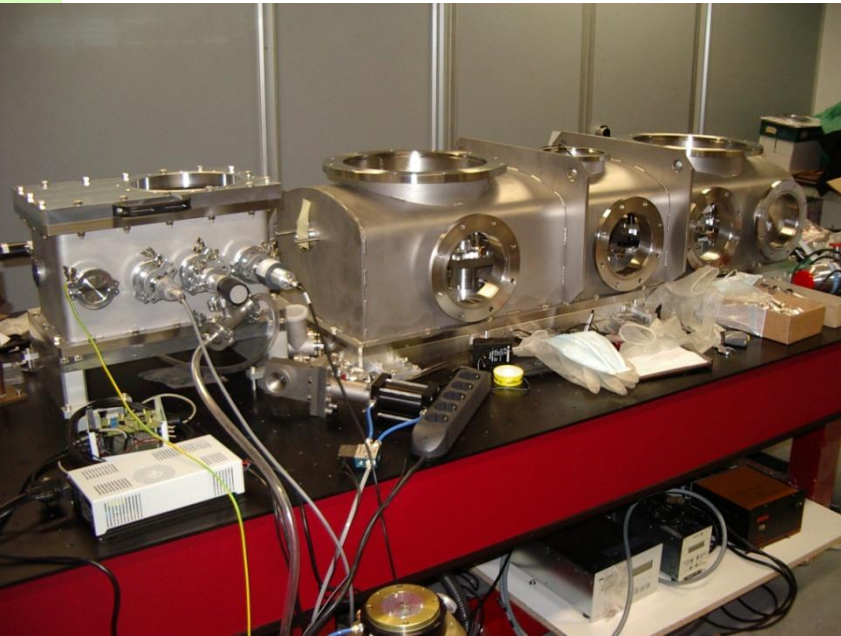

L. Poletto et al, CLEO 2006

Image performance, wavelength calibration, efficiency

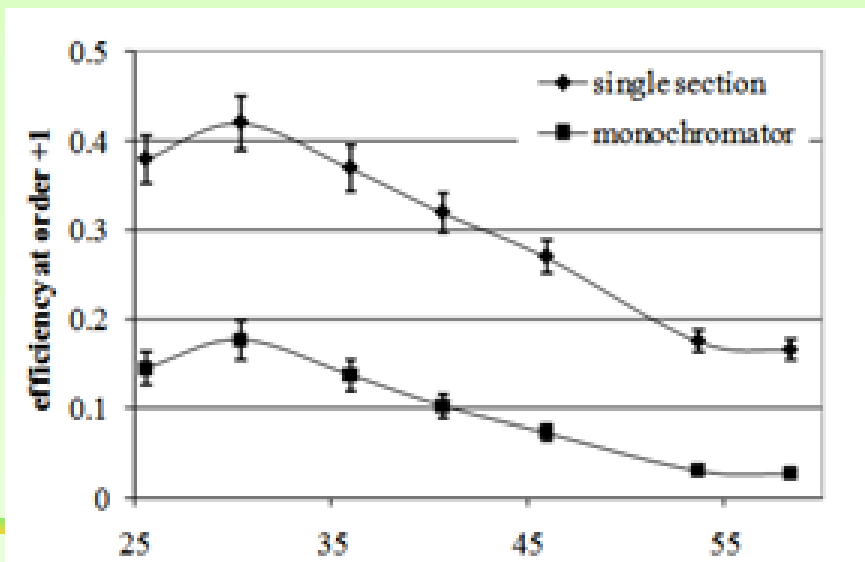
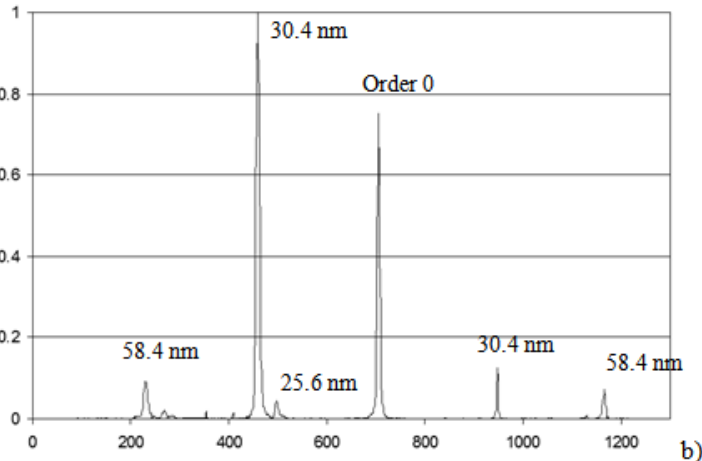
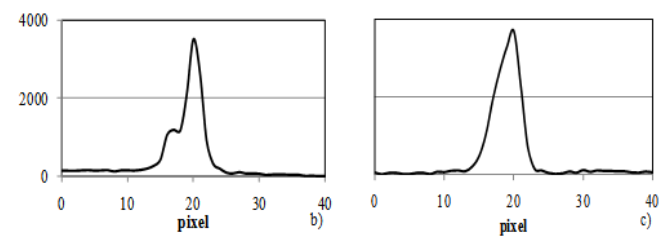
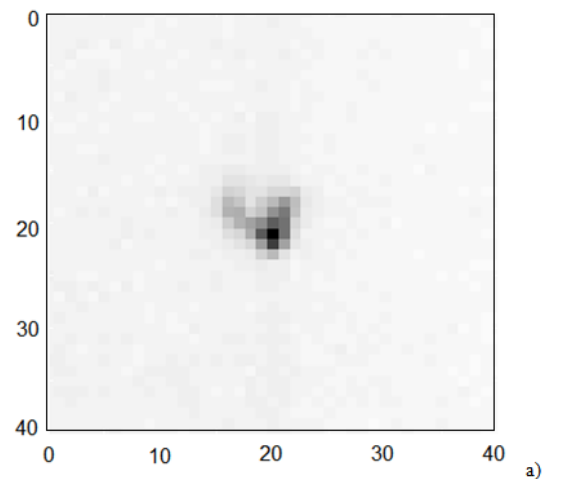
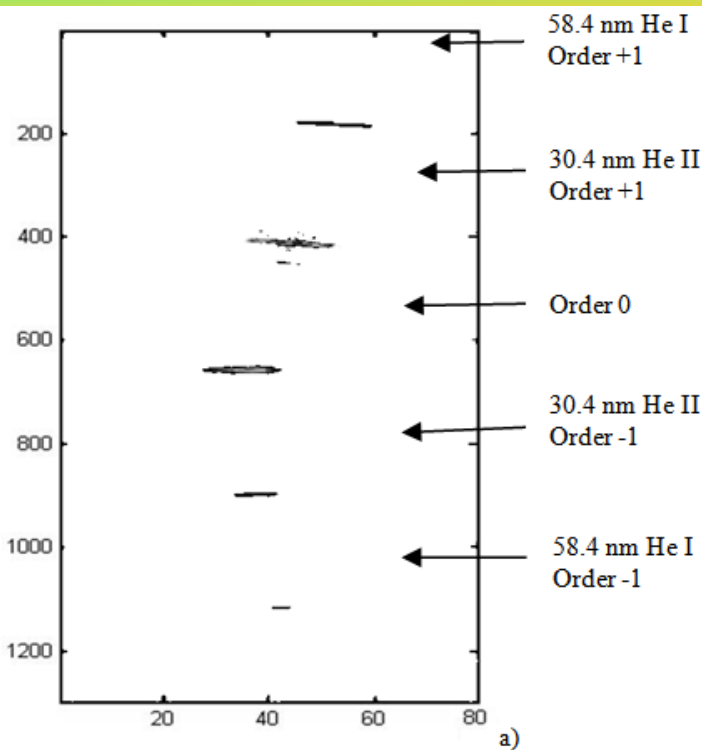

Temporal characterization

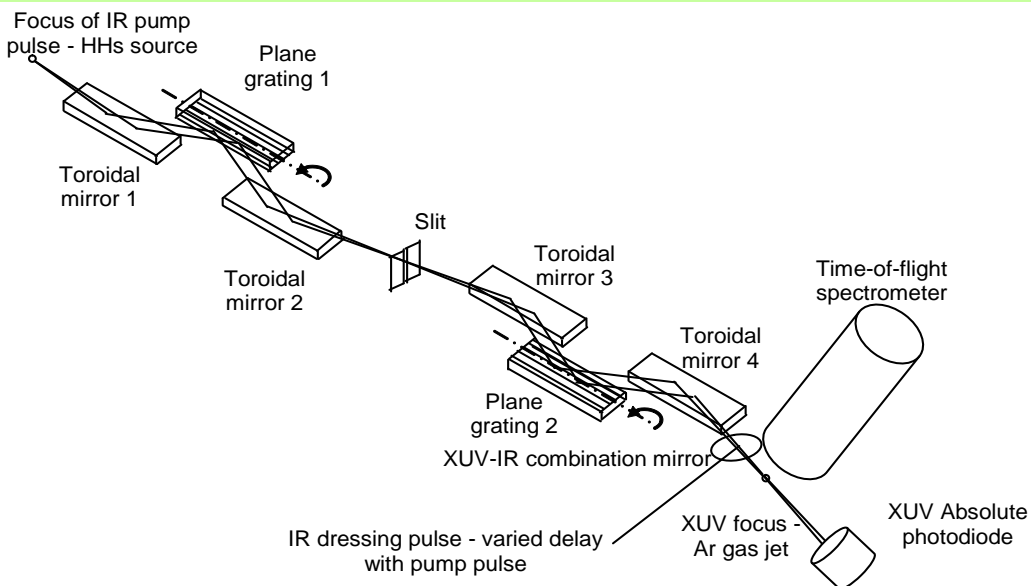

The temporal characterization is achieved by cross-correlation measurement of the XUV pulses with a synchronized 25-fs, 800-nm pulse at 1-kHz repetition rate. The harmonic pulse ionizes a gas in the presence of the IR field. When the two pulses overlap in time and space on a gas jet, sidebands appear in the photoelectron spectrum. The sideband amplitude as a function of the delay between the XUV and IR pulses provides the cross-correlation signal.

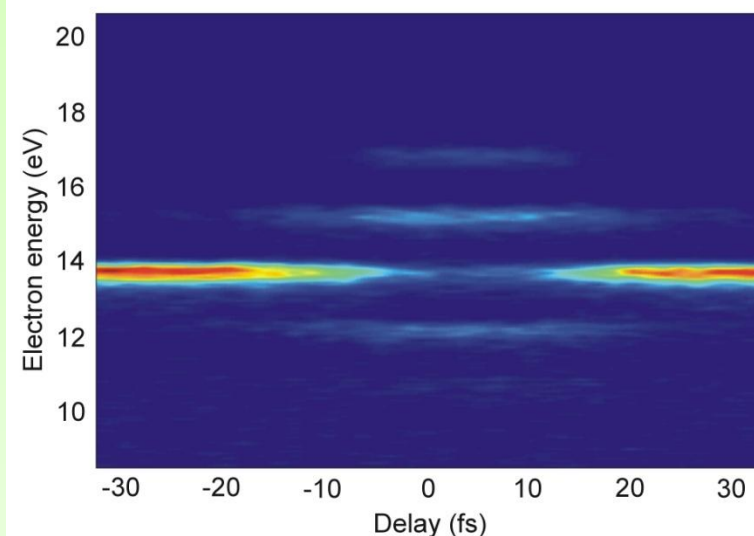
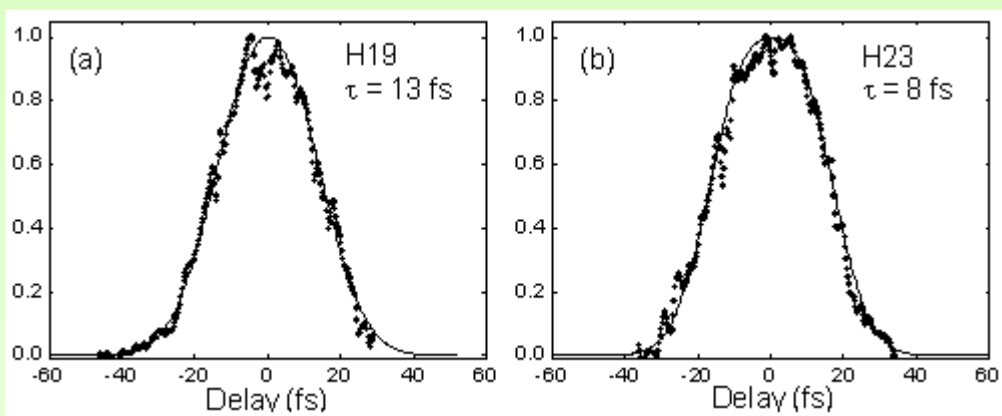

L. Poletto et al, *Opt. Lett.* **32**, 2897 (2007)

L. Poletto et al, *Rev. Sci. Inst.* **80**, 123109 (2009)

Trade-off in time preservation

Single grating design

- Increase of the pulse duration ($\cong 20-50$ fs range)
- Maximum throughput for a grating monochromator ($>30\%$ in the off-plane mount)
- Simple optical design

Double grating design

- Preservation of the pulse duration in the few-fs range
- Lower throughput because of the two gratings (15-20%)
- More complex optical design

Conclusions: time-preserving monochromator

- Time-preserving monochromators for ultrashort pulses (\approx few tens of femtoseconds) with gratings in the off-plane mount have been realized
- The spectral selection of HHs is performed within a broad spectral interval

- Single-grating configuration: residual temporal broadening
- Double-grating configuration: preservation of the pulse duration

- Off-plane design can be applied also to beamlines for free-electron-laser radiation
 - High efficiency
 - Low temporal broadening

- Classical diffraction design is suitable for responses in the 100-200 fs time scale

People involved at LUXOR

Dr. Fabio Frassetto

Dr. Stefano Coraggia

Prof. Paolo Villoresi

Dr. Luca Poletto

**CNR - Institute of Photonics and Nanotechnologies
LUXOR - Laboratory for UV and X-Ray Optical Research
Padova, Italy**

Contact person: poletto@dei.unipd.it